

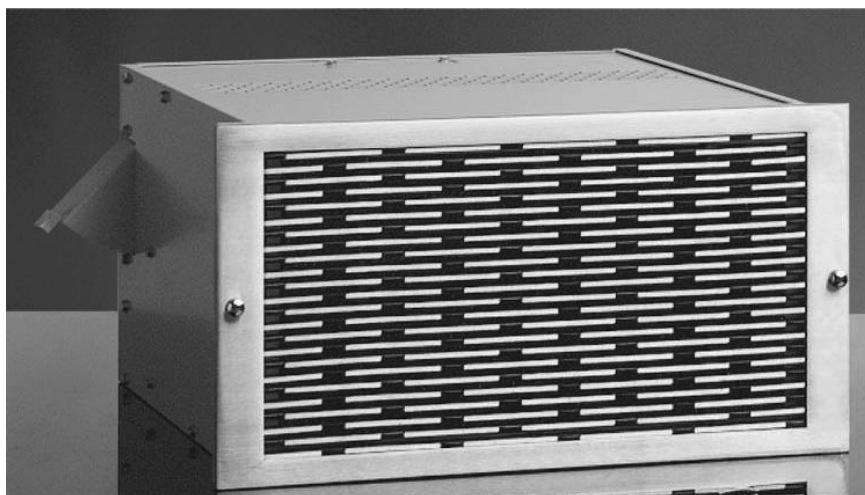

INSTRUCTION MANUAL FOR:

RCR11 AIR CONDITIONER



MAI/Prime Parts
5736 N. Michigan Road Indianapolis, IN 46228
Tel: 317-257-6811 Fax: 317-257-1590

WWW.MCLEANPARTS.NET

TABLE OF CONTENTS

Receiving the Air Conditioner	1
Handling and Testing the Air Conditioner	1
Installation	2
Design Data, Model Drawing	3
Mounting Instructions.....	4
Components List.....	4
Wire Diagrams	5
Temperature Control.....	6
Principles of Operation	6
Maintenance	6
Trouble Shooting	8

NOTE: Some of the information in this manual may not apply if a special unit was ordered. If additional drawings for a special unit are necessary, they have been inserted. Contact McLean Thermal if further information is required.

RECEIVING THE AIR CONDITIONER

Inspect the air conditioner. Check for concealed damage that may have occurred during shipment. Look for dents, scratches, loose assemblies, evidence of oil, etc. Damage evident upon receipt should be noted on the freight bill. Damage should be brought to the attention of the delivering carrier -- NOT to McLean Thermal-- within 15 days of delivery. Save the carton and packing material and request an inspection. Then file a claim with the delivering carrier.

McLean Thermal cannot accept responsibility for freight damages; however, we will assist you in any way possible.

HANDLING & TESTING THE AIR CONDITIONER

If it is necessary to place the air conditioner in a horizontal position after unpacking, be certain it is placed in an upright, vertical or mounting position for a minimum of five (5) minutes before operating.

Never attempt to operate the air conditioner while it is horizontal or on its' side, back or front. The refrigeration compressor is filled with lubricating oil. Running the compressor without oil in the lower part of the housing will cause permanent damage to the air conditioner. This also voids the warranty.

TEST FOR FUNCTIONALITY BEFORE MOUNTING THE AIR CONDITIONER TO THE ENCLOSURE.

Refer to nameplate for proper electrical current requirements, and then connect power cord to a properly grounded power supply. Minimum circuit ampacity should be at least 125% of the amperage shown in the design data section for the appropriate model. No other equipment should be connected to this circuit to prevent overloading.

317-257-6811

WWW.McLeanParts.net

317-257-1590 fax

Operate the air conditioner for five (5) to ten (10) minutes. No excessive noise or vibration should be evident during this run period. The condenser blower (ambient air), the evaporator impeller (enclosure air), and the compressor should be running. Condenser air temperatures should be warmer than normal room temperatures within a few minutes.

The compressor is provided with automatic reset thermal overload protection. This thermo-switch is located and mounted inside the plastic enclosure clipped to the compressor. The switch operates when the compressor overheats due to clogged or dirty inlet air filter or if ambient air temperatures exceed nameplate rating or if enclosure dissipated heat loads exceed the rated capacity of the air conditioner. The thermal overload switch will actuate and stop compressor operation. The blowers will continue to operate and the compressor will restart after it has cooled to within the thermal overload cut-in temperature setting.

INSTALLATION

Step 1: Inspect air conditioner. Verify functionality before mounting the air conditioner, see Handling & Testing the Air Conditioner on page 1.

Step 2: Determine if the unit is to be surface or recess mounted. Using the appropriate cutout dimensions shown on page 5 of this manual, prepare the enclosure opening for either surface or recess mounting.

Step 3: Using the gasket kit provided, install gaskets to air conditioner.

Step 4: Mount air conditioner on enclosure using mounting bolts and screws provided (mounting hardware is not provided for recess mount units). Allow unit to remain upright for a minimum of five (5) minutes before starting. Caution: Air conditioner must be in upright position during operation.

Step 5: Refer to top of nameplate for electrical requirements. Connect the power cord to a properly grounded power supply. Use of an extension cord is not recommended. Electrical circuit should be fused with slow blow or HACR circuit breaker.

RCR11 Series

2000-4000 BTU/Hr. (586 - 1172 Watts)

H x W x D: 10.47" (266) x 19" (483) x 21.47" (545)

Model	Voltage	Hz	Amps	Full Load Phase	BTU/Hr @ Max Amb Temp	Max Amb Temp °F/°C	Shipping Weight Lbs/Kgs
RCR11-0216-GXXX	115	50/60	9.0/9.0	1	1800/2000	131/55	95 lbs.
RCR11-0226-GXXX	230	50/60	5.1/4.7	1	1800/2000	131/55	95 lbs.
RCR11-0416-GXXX	115	50/60	12.9/12.9	1	3800/4000	131/55	105 lbs.
RCR11-0426-GXXX	230	50/60	7.1/7.1	1	3800/4000	131/55	105 lbs.

XXX will be replaced with a three-digit number designating all desired options. Consult the factory for specific model numbers.

RCR11 Model Drawing

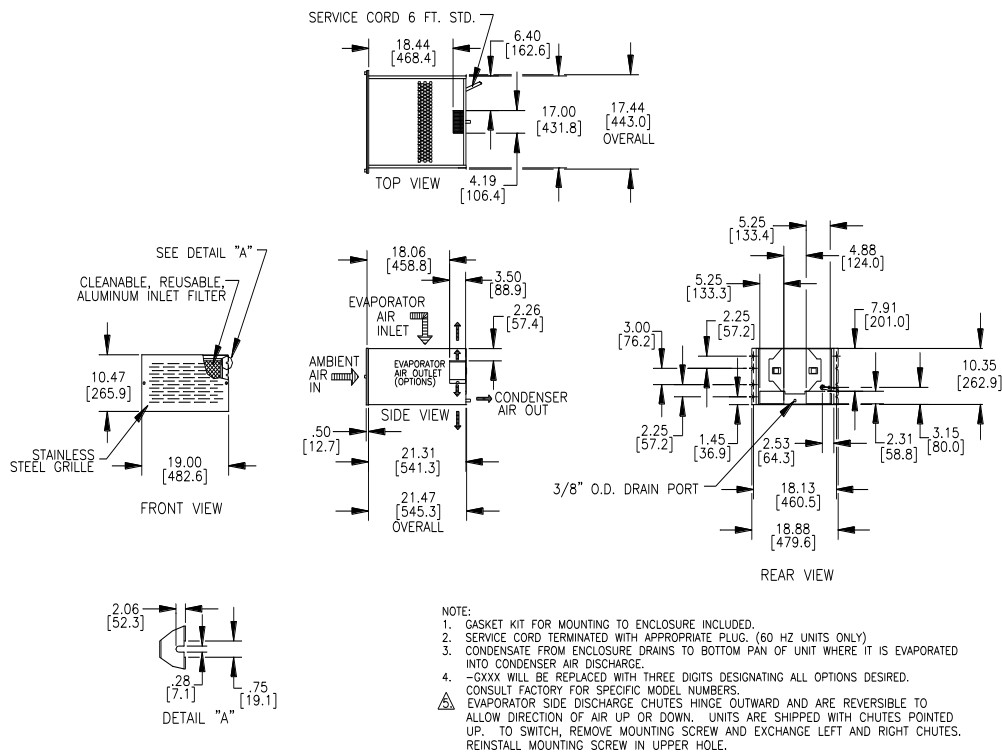

317-257-6811

WWW.McLeanParts.net

317-257-1590 fax

RCR11 Mounting Cutout Dimensions

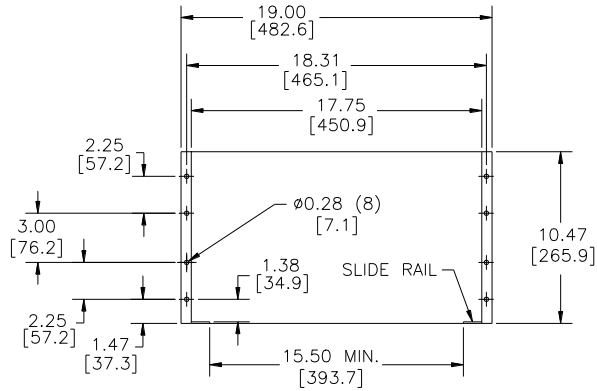

RCR11 Series Components List

Part Description	Part Number (115 Volt)		Part Number (230 Volt)	
	2000 BTU	4000 BTU	2000 BTU	4000 BTU
Blower, Condenser	28-1064-01M	38-2019-04	28-1064-02M	38-2020-04
Blower, Evaporator	10-1091-121	10-1091-121	10-1091-122	10-1091-122
Capacitor, Compressor, Start/Run	N/A	10-1032-13	10-1032-09	10-1032-14
Coil, Condenser	11-3001-00	11-3001-00	11-3001-00	11-3001-00
Coil, Evaporator	11-1002-00	11-1002-00	11-1002-00	11-1002-00
Compressor, AE/AK	10-1016-22	10-1016-26	10-1026-74	10-1026-77
Condenser Discharge Duct	11-6037-00	11-6037-00	11-6037-00	11-6037-00
Filter, Air, Reusable	10-1000-12	10-1000-12	10-1000-12	10-1000-12
Filter/Dryer	52-6028-00	52-6028-00	52-6028-00	52-6028-00
Relay, Compressor, Start	10-1028-05	10-1028-14	10-1028-07	10-1028-15
Service Cord	52-6035-01	52-6035-0	52-6035-74	52-6035-75
Terminal Block	10-100303	10-1003-03	10-1003-03	10-1003-03
Thermal Overload, Compressor	10-1007-44	10-1007-45	10-1007-57	10-1007-51
Thermostat, SPST, 55-100F	52-6155-00	52-6155-00	52-6155-00	52-6155-00

317-257-6811

WWW.McLeanParts.net

317-257-1590 fax

RCR11 Wire Diagram

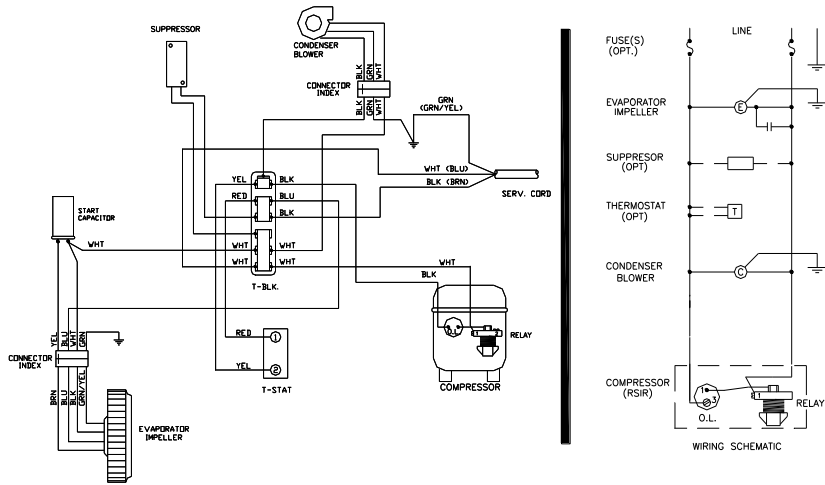

4000 BTU UNIT

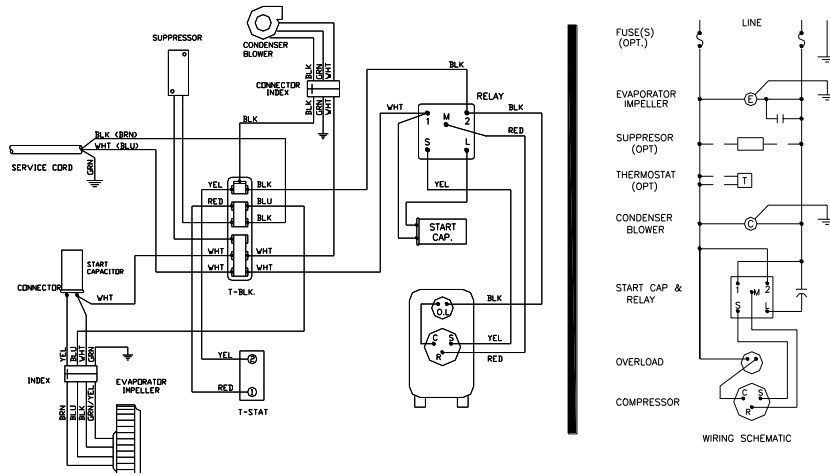

317-257-6811

WWW.McLeanParts.net

317-257-1590 fax

TEMPERATURE CONTROL

The electromechanical thermostat is factory preset to 75°F/23°C. To change the temperature setting, remove the nylon plug from the back face of the unit. Use a standard screwdriver to adjust thermostat. For cooler temperatures turn clockwise, for warmer temperatures turn counterclockwise.

PRINCIPLES OF OPERATION

If electrical power to the air conditioner is interrupted and reapplied immediately, (within 3 to 5 seconds), the compressor may not restart due to the high back pressure of the compressor. It takes a minimum of one (1) minute after shutdown for the compressor suction and discharge pressures to equalize in order for the air conditioner to restart.

Operating the air conditioner below the minimum ambient temperature or above the maximum ambient temperatures indicated on the nameplate voids all warranties.

It is recommended that the warranty section of this manual be read in order to familiarize yourself with parameters of restricted operation.

The moisture that the enclosure air can contain is limited. If moisture flows from the drain tube continuously this can only mean that ambient air is entering the enclosure. Be aware that frequent opening of the enclosure's door admits humid air that the air conditioner must then dehumidify.

MAINTENANCE

Compressor

The compressor requires no maintenance. It is hermetically sealed, properly lubricated at the factory and should provide years of satisfactory operating service.

Should the refrigerant charge be lost, recharging ports (access fittings) on the suction and discharge sides of the compressor are provided for recharging and/or checking suction and discharge pressures.

Under no circumstances should the access fitting covers be loosened, removed or tampered with.

Breaking of seals on compressor access fittings during warranty period will void warranty on hermetic system.

Recharging ports are provided for the ease and convenience of reputable refrigeration repair service personnel for recharging the air conditioner.

Inlet Air Filter

Proper maintenance of the inlet air filter, located behind the front grille, will assure normal operation of the air conditioner. If filter maintenance is delayed or ignored, the maximum ambient temperatures under which the unit is designed to operate will be decreased.

If the compressor's operating temperature increases above designed conditions due to a dirty or clogged filter (or plugged condenser coil), the air conditioner's compressor will stop operating due to actuation of the thermal overload cutout switch located on the compressor housing. As soon as the compressor temperature has dropped to within the switch's cut-in setting, the compressor will restart automatically. However the above condition will continue to take place until the filter has been cleaned or replaced.

317-257-6811

WWW.McLeanParts.net

317-257-1590 fax

Inlet Air Filter Con't

It is recommended that power to the air conditioner be interrupted intentionally when abnormally high compressor operating temperature causes automatic shutdown of the unit. The above described shutdown is symptomatic of clogged or dirty filter, thus causing a reduction in cooling airflow across the surface of the compressor and condenser coil.

Do not run the air conditioner for extended periods of time with the filter removed. Particles of dust, lint, etc., can plug the fins of the condenser coil, which will give the same reaction as a plugged filter. The condenser coil is not visible through the filter opening, so protect it with a filter.

Continued operation under the above conditions can and will damage and shorten compressor life. The air conditioner features an easily removable inlet filter to facilitate necessary cleaning. There should be no reason to neglect this necessary maintenance.

How To Remove, Clean or Install a New Inlet Air Filter

RP aluminum washable air filters are designed to provide excellent filtering efficiency with a high dust holding capacity and a minimum amount of resistance to air flow. Because they are constructed entirely of aluminum they are lightweight and easy to service. Optimum filter performance is maintained by recoating the filters after washing with RP Super Filter Coat adhesive. To achieve maximum performance from your air handling equipment, air filters should be cleaned on a regular basis.

The inlet air filter is located behind the front grille. To remove the grille, remove (2) screws and pull top edge of grille forward. The filter may now be removed and cleaned or new filter installed. Reinstall grille.

Cleaning Instructions:

1. Flush the filter with warm water from the exhaust side to the intake side. **DO NOT USE CAUSTICS.**
2. After flushing allow filter to drain. Placing it with a corner down will assure complete drainage.
3. Recoat the filters with RP Super Filter Coat adhesive. When spraying filter do so from both sides for maximum concentration of adhesive.

Condenser and Evaporator Air Movers

Blower and impeller motors require no maintenance. All bearings, shafts, etc. are lubricated during manufacturing for the life of the motor.

If the condenser blower motor (ambient blower) should fail, it is not necessary to remove the air conditioner from the cabinet or enclosure to replace the blower. The condenser blower is mounted on its own bulkhead and is easily accessible by removing the front cover.

Caution: Operation of the air conditioner in areas containing airborne caustics or chemicals can rapidly deteriorate filters, condenser coils, blowers and motors, etc. Contact McLean Thermal for special recommendations.

Refrigerant Loss

Each air conditioner is thoroughly tested prior to leaving the factory to insure against refrigeration leaks. Shipping damage or microscopic leaks not found with sensitive electronic refrigerant leak detection equipment during manufacture may require repair or recharging of the system. This work should only be performed by qualified professionals, generally available through a local, reputable air conditioning repair or service company.

Refer to the data on the nameplate, which specifies the type of refrigerant and the charge size in ounces.

Before recharging, make sure there are no leaks and that the system has been properly evacuated into a deep vacuum.

TROUBLE SHOOTING

Basic Air Conditioning Trouble Shooting Check List

1. Check manufacturer's nameplate located on the unit for correct power supply.
2. Turn the power to the unit on. The evaporator (Enclosure or "COLD" air) blower should come on. Is there airflow?

YES, proceed to step # 3.

NO, possible: Open motor winding
 Stuck blower motor
 Obstructed wheels/blades

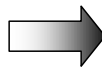

Repair or Replace defective part

Formatted

3. Check thermostat setting? Adjust thermostat to the lowest setting. This should turn the condenser blower and the compressor on. Did condenser blower and compressor come on when the thermostat was turned on?

YES, proceed to step #4.

NO, possible: Defective thermostat

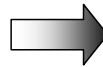

Replace part

Formatted

4. Are both blowers and the compressor running? If not the unit will not cool properly.
5. Check condenser (Ambient or "HOT" air) blower for airflow. Is there airflow?

YES, proceed to step # 6.

NO, possible: Defective thermostat
 Open motor winding
 Stuck blower motor
 Obstructed wheels/blades

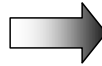

Repair or Replace defective part

Formatted

6. Carefully check the compressor for operation - motor should cause slight vibration, and the outer case of the compressor should be warm.

YES, wait 5 minutes, then proceed to step #7.

NO, possible: Defective thermostat
 Defective capacitor
 Defective overload
 Defective relay



Repair or Replace defective part

Formatted

7. Make sure the coils are clean. Then check evaporator "air in" and "air out" temperatures. If the temperatures are the same:

Possible loss of refrigerant
Possible bad valves in the compressor



Repair or Replace defective part

Formatted

8. To check for a bad thermostat. Turn power to the unit off. Remove control box cover, place both thermostat wires onto one terminal (replace control box cover for safety). This will pass the switch in the thermostat. Turn the power on. If both blowers and the compressor come on, the thermostat needs to be replaced.

Symptoms and Possible Causes:

SYMPTOM	POSSIBLE CAUSE
Unit won't cool	<ul style="list-style-type: none">* Blowers/impellers not running* Compressor not running* Compressor runs, but has bad valves* Loss of refrigerant
Compressor tries to start but won't run	<ul style="list-style-type: none">* Low line voltage at start. Should be +/-10% rated voltage* Compressor motor stuck* Bad relay* Bad overload switch* Bad run/start capacitor
Unit blows breakers	<ul style="list-style-type: none">* Under sized breaker/fuse or not time delayed* Short in system
Getting water in enclosure	<ul style="list-style-type: none">* Drain plugged* Drain tube kinked* Enclosure not sealed (allowing humidity in)

For additional technical information (i.e., amp draw, pressures, temperatures) contact MAI at 317-257-6811.