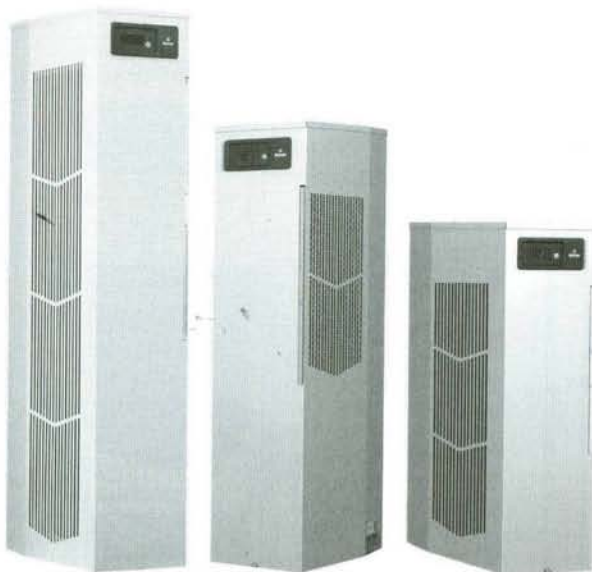

SPECTRACOOL™ Narrow Indoor/Outdoor

N43 11000 BTU/Hr. 3223 Watt	N36 6000/8000 BTU/Hr. 1758/2344 Watt	N28 4000 BTU/Hr. 1172 Watt
--	---	---

Industry Standards

UL/cUL Listed; Type 12, 3R, 4; 4X optional; File No. SA6453

CE
 IP 56 Internal Loop
 IP 34 on External Loop
 Telcordia GR-487 capable (Outdoor)

Application

- Industrial automation
- Waste water treatment systems
- Package handling equipment
- Security and defense systems

Features

- Narrow design accommodates 12-in. (300-mm) deep cabinets
- Energy efficient rotary compressor
- R407c and R134a earth-friendly refrigerants
- Models for 115, 230 and 400/460 3-phase VAC power input
- UL Listed to save customers time and money with agency approvals
- Outdoor model operating temperature range from -40 F/-40 C to 131 F/55 C
- Attractive industrial design with minimal use of visible fasteners
- Reliable mechanical thermostat on enclosure side of the unit; indoor Air Conditioner models include digital display on ambient side
- Galvanized sheet-metal cover for rugged factory and outdoor environments
- Easy-mount flanges for simple installation
- Cut-out adapter options for enclosures with McLean GENESIS® air conditioners enable users to easily transition to the new unit
- Dust-resistant condenser coil allows the unit to be run filterless in most applications
- Cleanable, reusable aluminum mesh filter protects coils for maximum cooling performance
- Mounting hardware, gaskets and user manual furnished with the unit
- Every unit functionally tested before shipping
- Standard Indoor Air Conditioner models also include:
 - Active condensate management with heater strip
 - Power-off relay for door switch and other system requirements
 - Malfunction switch
- Standard Outdoor Air Conditioner models also include:
 - Telcordia GR-487 capable
 - Corrosion-resistant components
 - Malfunction switch
 - Compressor heater
 - Head pressure control
 - 1300 W enclosure heater

Specifications

- Nominal cooling capacity:
 - N28 4000 BTU/Hr. (1172 W)
 - N36 6000 & 8000 BTU/Hr. (1758 and 2344 W)
 - N43 11000 BTU/Hr. (3223 W)
- Outdoor model operating temperature range from -40 F/-40 C to 131 F/55 C

Finish

- RAL 7035 light-gray, semi-textured powder-coat paint
- Other colors and textures available

Notes

Air Conditioners

 Performance Data **N28 4000 BTU/Hr. (1172 Watt)**

CATALOG NUMBER			
Indoor Model	N280416G050	N280426G050	N280425G050
Indoor Model Stainless Steel Type 4X	N280416G051	N280426G051	N280425G051
Outdoor Model without Heat Pkg.	N280416G100	N280426G100	N280425G100
Outdoor Model without Heat Pkg. Stainless Steel Type 4X	N280416G102	N280426G102	N280425G102
Outdoor Model with Heat Pkg.	N280416G150	N280426G150	N280425G150
Outdoor Model with Heat Pkg. Stainless Steel Type 4X	N280416G151	N280426G151	N280425G151
COOLING PERFORMANCE			
Nominal:			
BTUs/Hr.	3800 / 4000	3800 / 4000	3800 / 4000
Watts	1114 / 1172	1114 / 1172	1114 / 1172
At 131 F / 131 F (55 C / 55 C):			
BTU/Hr. (50 / 60 Hz)	3805 / 4162	4394	3818
Watts (50 / 60 Hz)	1115 / 1220	1288	1119
At 95 F / 95 F (35 C / 35 C):			
BTU/Hr. (50 / 60 Hz)	3589 / 3974	3690	3298
Watts (50 / 60 Hz)	1052 / 1165	1081	967
Refrigerant	R134a	R134a	R134a
Refrigerant Charge (ounces/grams)	11 / 312	11 / 312	11 / 312
Operating Temperature Range:			
Maximum (°F / °C)	125/52	125/52	125/52
Minimum (°F / °C)	-40/-40	-40/-40	-40/-40
Air Flow at 0 Static Pressure:			
Internal loop 50 Hz (CFM / M ³ /Hr)	138 / 234	N/A	138 / 234
External loop 50 Hz (CFM / M ³ /Hr)	268 / 455	N/A	268 / 455
Internal loop 60 Hz (CFM / M ³ /Hr)	143 / 362	143 / 243	N/A
External loop 60 Hz (CFM / M ³ /Hr)	288 / 728	288 / 489	N/A
Max. Heater W (Outdoor Models)	1300	1300	1300
ELECTRICAL DATA			
Rated Voltage	110 / 115	230	230
Frequency (Hz)	50 / 60	60	50
Operating Range	/-10%	/-10%	/-10%
Max. Power Consumption (Watts at 50 / 60 Hz)	1039 / 1191	1250	1111
Max. Nominal Current (Amps at 50 / 60 Hz)	11.6-11.2	6.5	5.8
Starting Current (Amps)	40	24.5	24.5
Agency Approvals		cUL Listed CE	
Power Input Description		Others available upon request Terminal Block	
ENCLOSURE PROTECTION			
UL Type		Type 12, 3R, 4 Standard Type 4X Stainless Steel Optional	
CONTROLLER			
Description		Basic Mechanical Thermostat	
Thermostat Location		Enclosure Side	
Factory Thermostat Setting (°F / °C)		80 / 27	
SOUND LEVEL			
At 1.5 Meters	66.1 dBA	65.5 dBA	65.5 dBA
UNIT CONSTRUCTION			
Material		Galvanized sheet metal standard Stainless steel optional	
Finish		RAL 7035 light-gray, semi-textured powder-coat paint standard Other colors available	
UNIT DIMENSIONS			
Height (in / mm)		28 / 711.2	
Width (in / mm)		11.50 / 292.1	
Depth (in / mm)		14.00 / 355.6	
Weight (lb / kg)	84/38	84/38	92/41.7

N28 Models 4000 BTU/Hr. (1172 Watt)

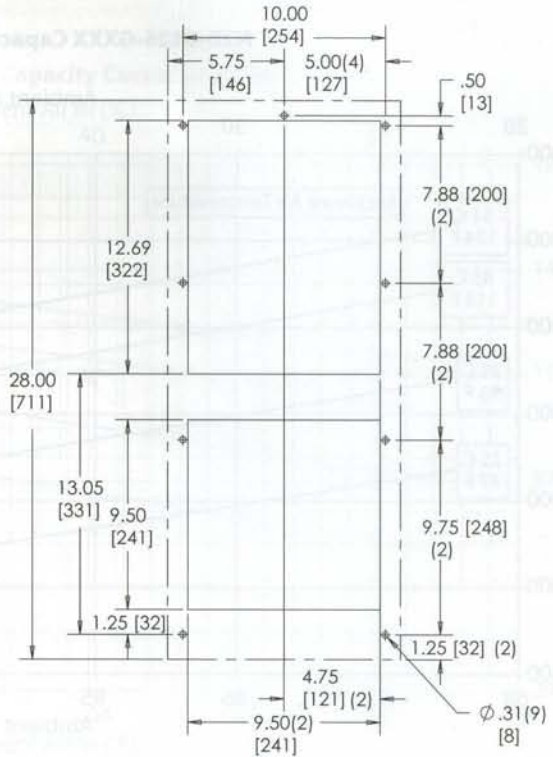
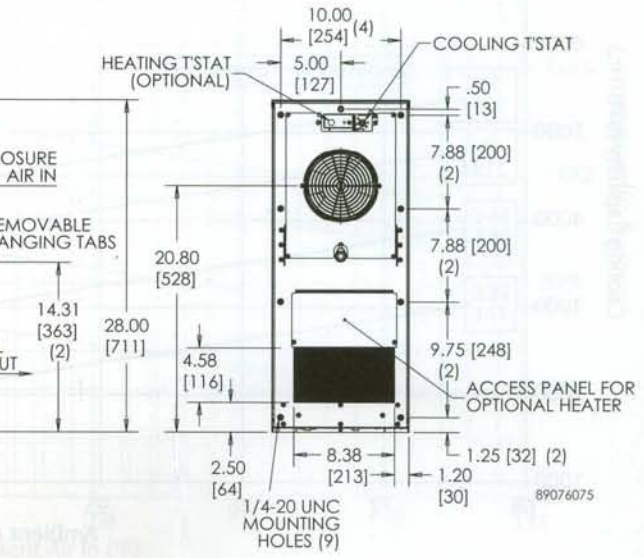
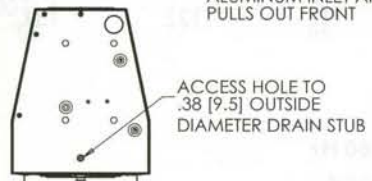
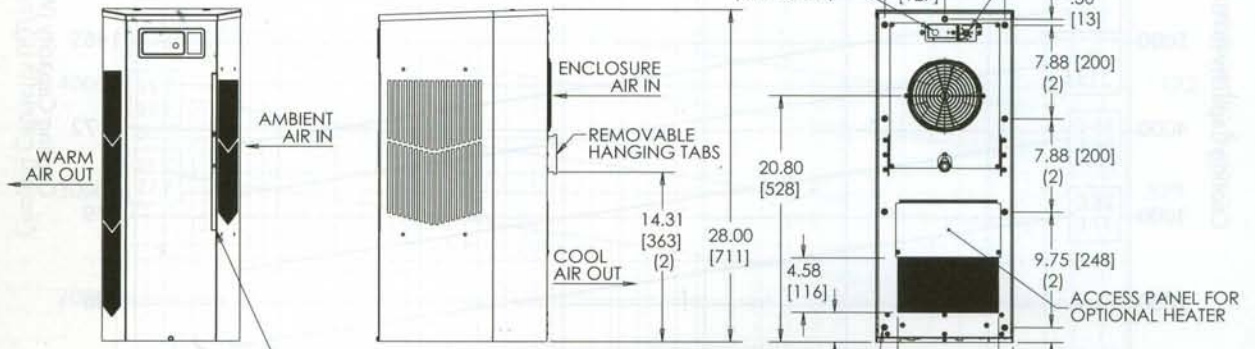
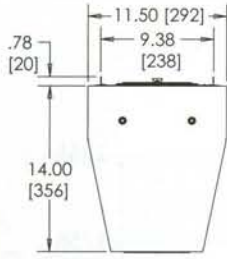

Cutout Dimensions

Sealed Enclosure Cooling