



**SPECTRACOOOL**  
AIR CONDITIONER, HAZARDOUS LOCATIONS  
NHZ36 MODEL

# INSTRUCTION MANUAL

DESIGN WITH CONFIDENCE™

# TABLE OF CONTENTS

General Safety Information .....	3
Receiving the Air Conditioner .....	3
Handling and Testing the Air Conditioner .....	4
How to Read Model Numbers .....	4
Technical Information.....	4
General.....	4
Sequence of Operation.....	4
Cooling.....	4
Standard and Optional Component Operation.....	5
SMART CONTROLLER .....	5
For cooling (75-100 F range) .....	5
Remote Access Control (optional).....	5
Head Pressure Control (optional).....	5
115V/230V to 10V Transformer (optional) .....	5
Door Switch .....	5
Active Condensate Management.....	5
When Used With Purge and Pressurized Enclosures .....	5
Schematics and Wiring Diagrams.....	6
Generic 1 PHASE Schematic (actual unit options may vary).....	6
Generic 3 PHASE Schematic (actual unit options may vary).....	6
Generic 1 Phase Wire Diagram (actual unit options may vary).....	7
Generic 3 PHASE Wire Diagram (actual unit options may vary) .....	8
Dimensional Drawing.....	9
General Safety Information.....	10
Installation Instructions .....	10
Smart Controller .....	12
Introduction .....	12
Energizing the Controller .....	12
Control Status Indication .....	12
Displaying and Changing Program Variables .....	13
Operating Parameters .....	13
Alarm Parameters .....	13
Displaying Temperature Sensor #2.....	13
Compressor Restart Time Delay .....	13
Alarm Output Contact.....	13
Alarm Input Connection.....	14
Alarm Condition Display .....	14
Remote Access Control.....	15
Air Conditioner Unit Communication Features .....	15
USB Communication.....	15
Ethernet Communication .....	15
Using the PC Interface Tool .....	16
USB COMMUNICATION MODE .....	16
Ethernet Communication Mode .....	17
Remote Access Control Pin-out.....	18
General Safety Information.....	18
Maintenance .....	19
Compressor.....	19
Inlet Air Filter .....	19
How To Remove, Clean or Install a New Inlet Air Filter .....	19
Condensate Management and Drain Trap Maintenance.....	19
Condenser and Evaporator Air Movers .....	20
Refrigerant Loss.....	20
Refrigerant Properties Chart (R134a) .....	20
6000 BTU/Hr. Unit Characteristics .....	21
8000 BTU/Hr. Unit Characteristics .....	22
Functional Data .....	23
Service Data.....	24
6000 BTU/Hr. Components List.....	24
8000 BTU/HR. Components List.....	25
NHZ360616GXXX Pressure Tables.....	26
NHZ360626GXXX Pressure Tables.....	27
NHZ360646GXXX Pressure Tables.....	28
NHZ360816GXXX Pressure Tables.....	29
NHZ360826GXXX Pressure Tables.....	30
NHZ360846GXXX Pressure Tables.....	31
Trouble Shooting.....	32
Basic Air Conditioning Trouble Shooting Check List - SMART CONTROLLER .....	32
Symptoms and Possible Causes - Remote Access Control Version .....	33
Warranty .....	34
Return and Repair Policy .....	34
Limitation of Liability .....	35

## GENERAL SAFETY INFORMATION

Please observe the following general safety instructions when assembling and operating the unit:

- Assembling, installing and servicing must only be performed by properly trained specialists.
- When transporting the enclosure with the cooling unit externally mounted, always use an additional shipping brace to support the cooling unit.
- Do not attempt to operate the air conditioner while it is horizontal or on its side, back or front.
- Operation of air conditioner in areas containing airborne caustics or chemicals can rapidly degrade sealing properties of materials, deteriorate filters, refrigeration coils, blowers and motors. Contact Pentair Equipment Protection for special recommendations. See Maintenance on page 19.



### DANGER



Danger: explosion hazard - do not energize, disconnect, or troubleshoot equipment unless power has been switched off or the area is known to be non-hazardous.

Unit to be installed and maintained by properly trained personnel only.

Danger : Risque d'explosion – Ne pas alimenter, déconnecter ni dépanner l'équipement si l'alimentation n'a pas été coupée ou si la zone n'est pas reconnue comme non dangereuse.

## RECEIVING THE AIR CONDITIONER

Inspect the air conditioner. Check for concealed damage that may have occurred during shipment. Look for dents, scratches, loose assemblies, evidence of oil, etc. Damage evident upon receipt should be noted on the freight bill. Damage should be brought to the attention of the delivering carrier -- NOT to Pentair Equipment Protection -- within 15 days of delivery. Save the carton and packing material and request an inspection. Then file a claim with the delivering carrier.

Pentair Equipment Protection cannot accept responsibility for freight damages; however, we will assist you in any way possible.



### CAUTION

### MISE EN GARDE

This air conditioner is suitable for use in Class 1, Division 2, Groups A, B, C, D T4A hazardous locations, or non-hazardous locations only. It is meant to be installed in an enclosure such that the field wiring and controls are only accessible with the use of a tool.

Do not attempt to operate the air conditioner while it is horizontal or on its side, back or front. The refrigeration compressor is filled with lubricating oil. This will cause permanent damage to the air conditioner and also voids the warranty.

Ce climatiseur peut être utilisé dans des zones dangereuses de Classe 1, Division 2, Groupes A, B, C, D T4A ou des zones non dangereuses uniquement. L'installation doit être effectuée dans une armoire de telle sorte que le câblage et les commandes sur le terrain ne soient accessibles qu'à l'aide d'un outil.

Ne pas essayer de faire fonctionner le climatiseur en position horizontale, ou posé sur le côté, l'arrière ou l'avant. Le compresseur de réfrigération est rempli d'huile lubrifiante. Cela endommagerait le climatiseur de manière permanente et annulerait la garantie.

## HANDLING AND TESTING THE AIR CONDITIONER

If the air conditioner has been in a horizontal position, be certain it is placed in an upright, vertical or mounting position for a minimum of five (5) minutes before operating.

TEST FOR FUNCTIONALITY BEFORE MOUNTING THE AIR CONDITIONER TO THE ENCLOSURE.

Refer to the nameplate for proper electrical current requirements, and then wire the unit to a properly grounded power supply using copper conductors only. Power supply wiring should be restrained after field installation to ensure no contact with internal fan. Minimum circuit ampacity should be at least 125% of the amperage shown on the unit nameplate. No other equipment should be connected to this circuit to prevent overloading

Immediately after applying power, the evaporator blower (enclosure air) should start running. Operate the air conditioner with the compressor running for five (5) to ten (10) minutes. You will need to set the cooling thermostat or controller setpoint below the ambient temperature to operate the compressor.

Condenser air temperatures should be warmer than normal room temperatures within a few minutes after the condenser impellers start.

See Sequence of Operation on page 4 for specifics on how the unit operates when powered up.

## HOW TO READ MODEL NUMBERS

NHZ36	04	2	6	G300
1	2	3	4	5

1. Identifies the type/family of air conditioner and the approximate height (i.e. NHZ36 = Narrow Hazardous Location family about 36 inches high).
2. This is the air conditioner's listed capacity in BTU/Hr. at rated conditions. (i.e. 06=6,000 BTU/Hr. at 131/131 F)
3. 1 = 115 Volt, 2 = 230 Volt, 4 = 460 Volt.
4. 6 = 50/60 Hz or 60 Hz only.
5. Unique set of numbers for each air conditioner which identifies the accessories on a model.

## TECHNICAL INFORMATION

### GENERAL

Sensor 2 monitors the enclosure return air temperature to prevent ice buildup on the evaporator coil. If the air temperature drops below -1 C, the compressor and condenser air mover(s) shut off. They turn back on when the temperature rises above 15 C.

The compressor and the air movers are equipped with overload protection to guard against excess current and temperatures.

### SEQUENCE OF OPERATION

The air conditioner comes standard with smart controller. During cooling modes, the evaporator fan will be running.

### COOLING

When the enclosure temperature is above the cooling set-point plus the cooling differential, the smart controller will call for cooling. The compressor is then energized through a solid state relay or contactor. The condenser impellers will start immediately if the unit is not equipped with an optional head pressure control switch. If the unit is equipped with an optional head pressure control switch, the condenser impellers will start once the refrigerant pressure reaches the pressure setting of the switch. Component specific information is listed below.

Operating the air conditioner below the minimum ambient temperature or above the maximum ambient temperatures indicated on the nameplate voids all warranties. DO NOT adjust cooling set-point to a temperature lower than 70 F. Doing so can increase the likelihood of frost buildup on the evaporator coil.

The moisture that the enclosure air can contain is limited. If moisture flows from the drain tube continuously this can only mean that ambient air is entering the enclosure. Be aware that frequent opening of the enclosure's door admits humid air that the air conditioner must then dehumidify.

## STANDARD AND OPTIONAL COMPONENT OPERATION

### SMART CONTROLLER

The standard NHZ36 air conditioner uses our standard smart controller. The setpoint equals the temperature that the air conditioner turns off. The controller has a 7 F differential from setpoint until it calls for cooling. An example of operation is shown below.

#### FOR COOLING (75-100 F RANGE)

- Thermostat setpoint = 80 F
- Cooling turns on at 87 F
- Cooling turns off at 80 F

### REMOTE ACCESS CONTROL (OPTIONAL)

See Remote Access Control on page 15

### HEAD PRESSURE CONTROL (OPTIONAL)

Unit is set at the factory, no adjustment necessary.

At a saturated condenser temperature of 85 F (95 psig), the condenser fans will power off. At a saturated condenser temperature of 117 F (165 psig), the condenser fans will power on.

### 115V/230V TO 10V TRANSFORMER (OPTIONAL)

This transformer powers the thermal display.

### DOOR SWITCH

Several door switches may be connected in series and operated on one cooling unit. The door switch only supports a floating connection, no external voltages. Remove jumper from terminals 3 and 4 of the connector and connect the door switch to the two terminals if a door switch is available.

### ACTIVE CONDENSATE MANAGEMENT

At low temperatures and high humidity levels inside the enclosure, condensation may form on the evaporator coil.

The air conditioner will continuously evaporate the water that may be in the drain pan due to condensation from the evaporator coil into the external air stream. Excess condensate is routed downwards out of the air conditioner via a tube fitting at the bottom of the condenser side of the unit. A 10 mm inside diameter tube can be attached to the fitting and routed to a nearby drain.

### WHEN USED WITH PURGE AND PRESSURIZED ENCLOSURES

This air conditioner will operate safely in a Class 1 Division 2 Groups A, B, C and D hazardous location on both exterior and interior sides. It does not require a purge and pressurized enclosure, but if it is to be installed on one, the following should be considered.

The active condensate management system functionally described above is possible due to a drain trap directly connecting and routing condensation from the evaporator coil pan to the ambient side where it collects in the condensate evaporator pan.

During initial purging of an enclosure or after long periods of operation in a pressurized system utilizing a dry protective and/or inert gas supply, the drain trap can eventually dry out and allow a small amount of protective gas to leak outward of the enclosure through the drain trap. A leakage should not immediately be associated with a hazardous condition. If continuous positive pressure is maintained inside an enclosure, the protective gas will leak out to ambient and prevent hazardous gasses from entering. A typical enclosure pressurization system can compensate for this and maintain proper enclosure pressure.

If the pressurization system cannot compensate for the additional leakage, a drain trap seal can be created by priming the air conditioner drain. This can be done by de-energizing and opening the enclosure for access to the evaporator coil, and carefully pouring clean water (approx. 1 cup) into the face of the coil. With water present, the drain trap should be fully primed and sealed. Opening the enclosure can also introduce humidity back into the enclosure which will eventually condense on the evaporator coil and become part of the seal in the drain trap.

# SCHEMATICS AND WIRING DIAGRAMS

## GENERIC 1 PHASE SCHEMATIC (ACTUAL UNIT OPTIONS MAY VARY)

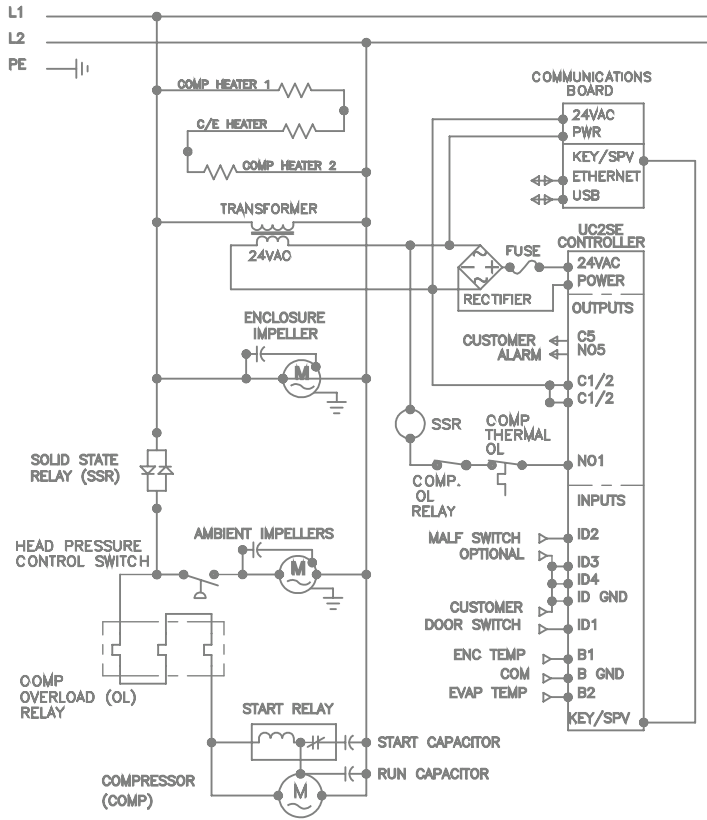

89123187 REV. A

## GENERIC 3 PHASE SCHEMATIC (ACTUAL UNIT OPTIONS MAY VARY)

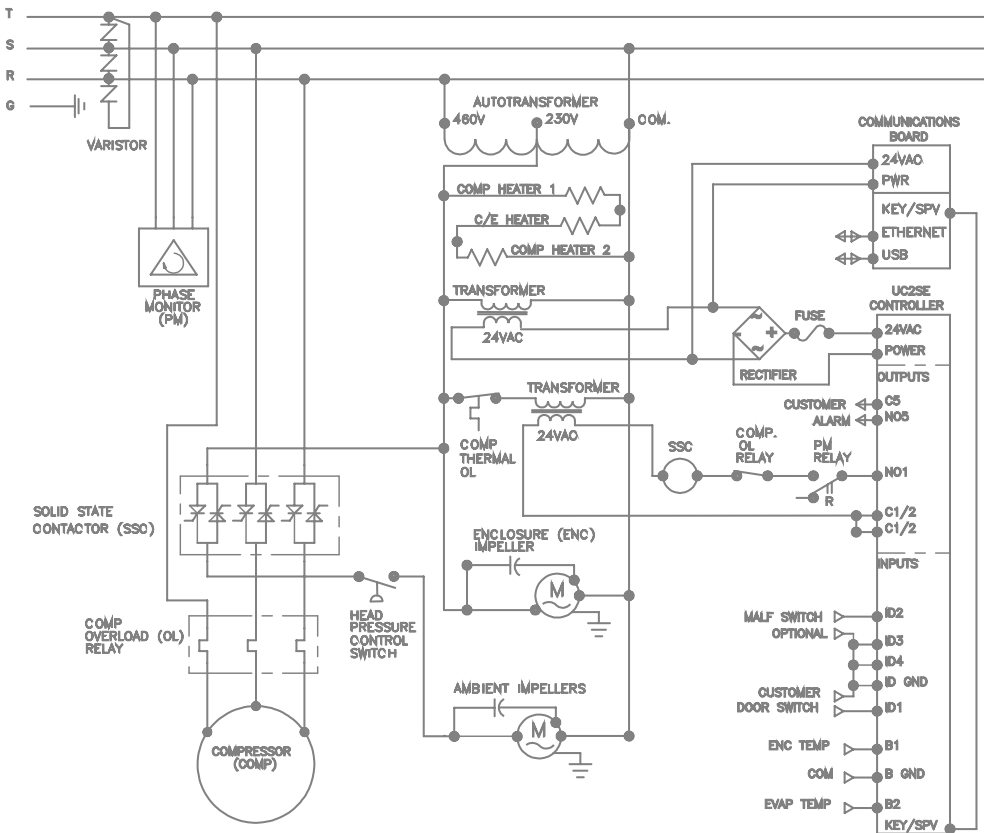

89123188 REV. B

# GENERIC 1 PHASE WIRE DIAGRAM (ACTUAL UNIT OPTIONS MAY VARY)

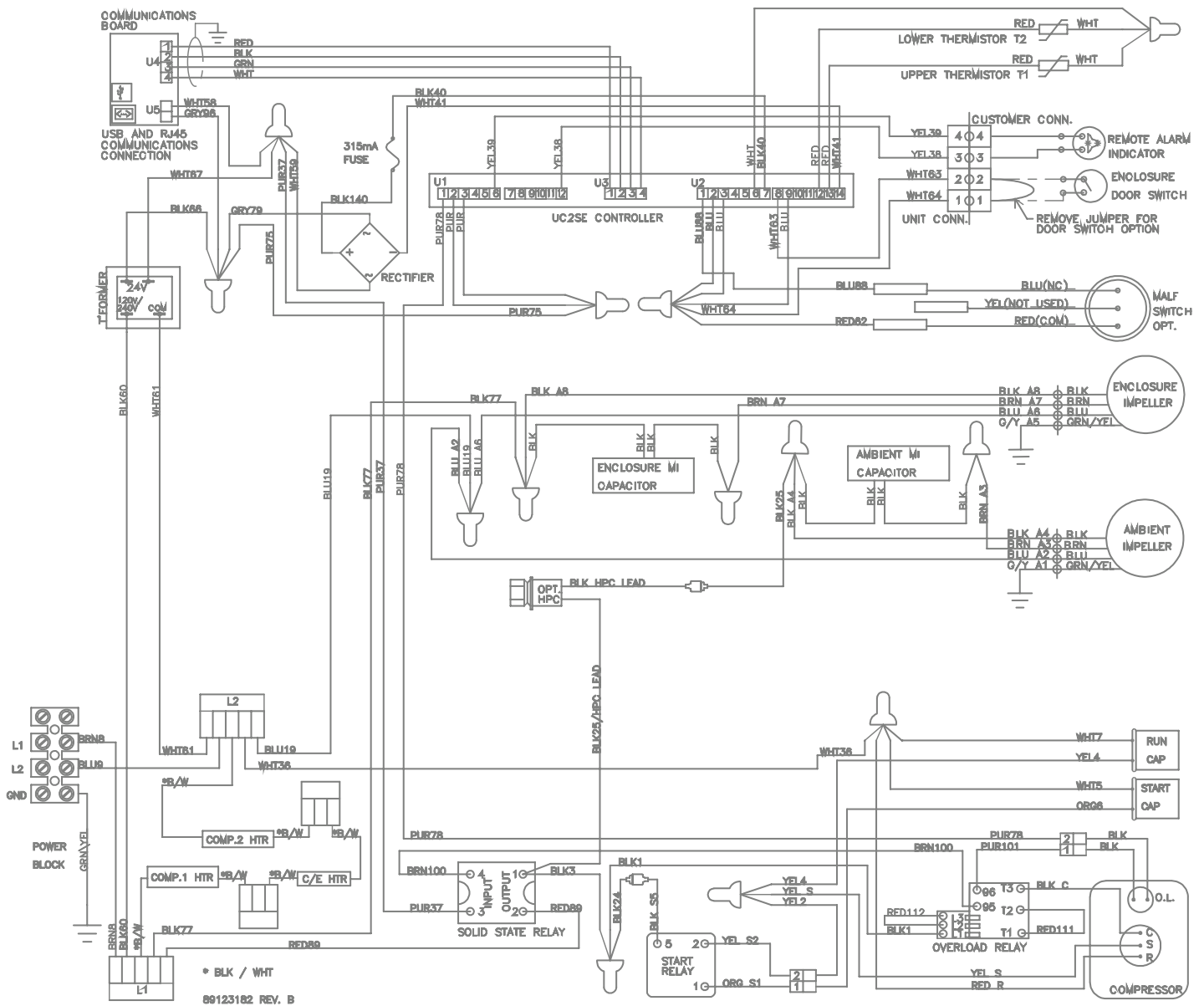

# GENERIC 3 PHASE WIRE DIAGRAM (ACTUAL UNIT OPTIONS MAY VARY)

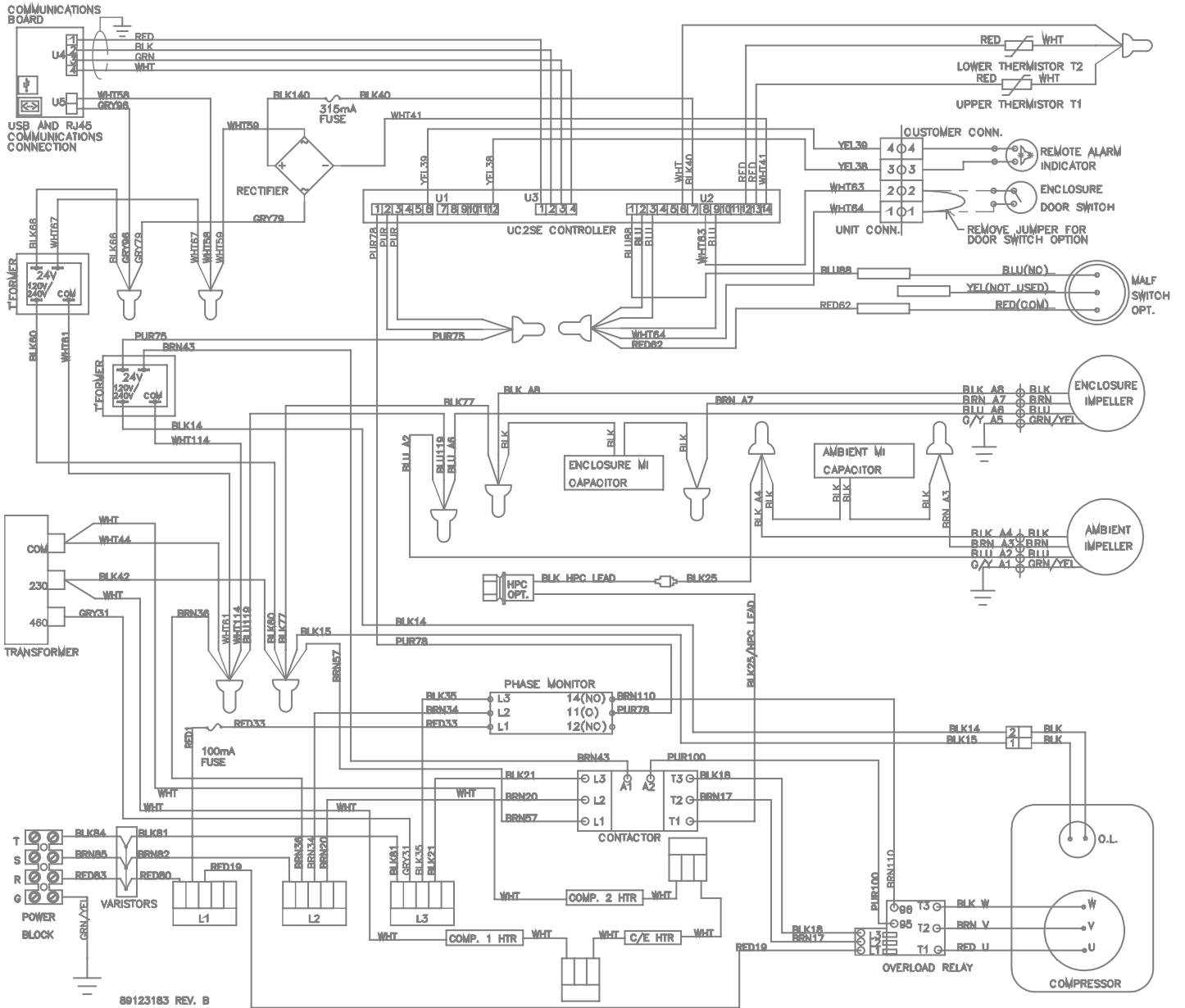



# DIMENSIONAL DRAWING

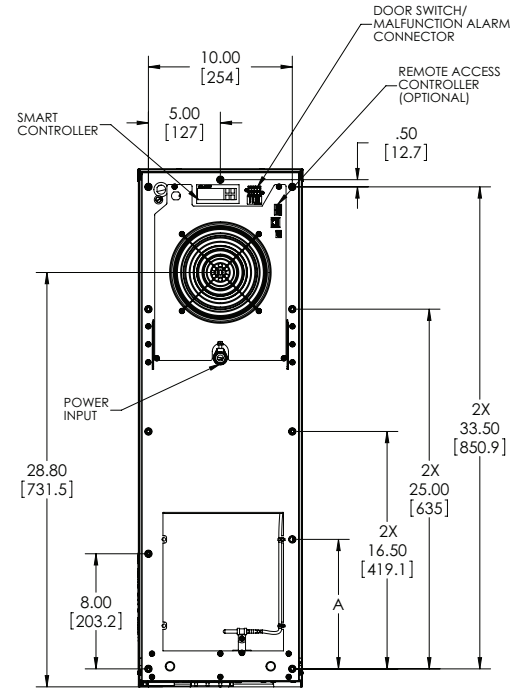
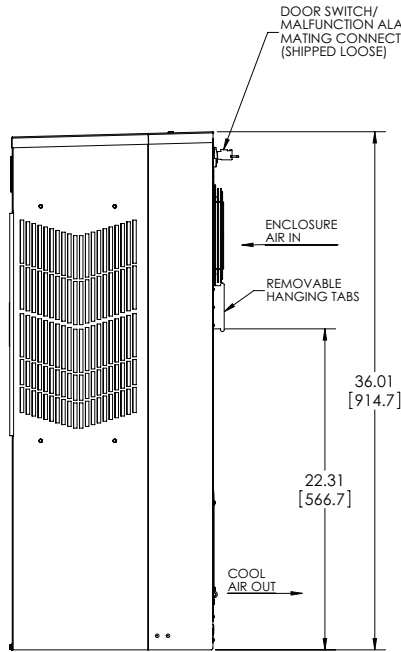
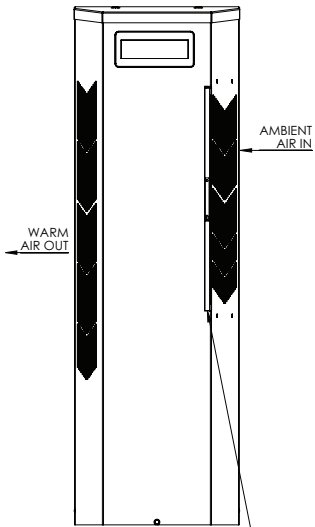
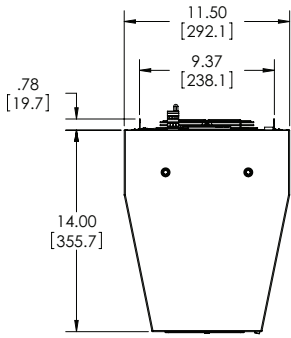

CLEANABLE, REUSABLE  
ALUMINUM INLET AIR FILTER  
PULLS OUT FRONT

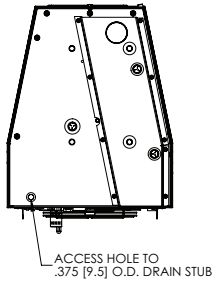

## GENERAL SAFETY INFORMATION

Please observe the following general safety instructions when assembling and operating the unit:

- Assembling, installing and servicing must only be performed by properly trained specialists.
- When transporting the enclosure with the cooling unit externally mounted, always use an additional shipping brace to support the cooling unit.
- Do not attempt to operate the air conditioner while it is horizontal or on its side, back or front.
- Operation of air conditioner in areas containing airborne caustics or chemicals can rapidly degrade sealing properties of materials, deteriorate filters, refrigeration coils, blowers and motors. Contact Pentair Equipment Protection for special recommendations. See Maintenance on page 19.



### DANGER



Danger: explosion hazard - do not energize, disconnect, or troubleshoot equipment unless power has been switched off or the area is known to be non-hazardous.

Unit to be installed and maintained by properly trained personnel only.

Danger: Risque d'explosion – Ne pas alimenter, déconnecter ni dépanner l'équipement si l'alimentation n'a pas été coupée ou si la zone n'est pas reconnue comme non dangereuse.

## INSTALLATION INSTRUCTIONS

1. Refer to nameplate for hazardous location rating.
2. Install a suitable switch to de-energize the air conditioner for repairs or remove the fuse.
3. Inspect the air conditioner and verify correct functionality before mounting the air conditioner. See Handling and Testing the Air Conditioner on page 4.
4. Using the mounting gasket kit provided with the unit, install gaskets to the air conditioner.
5. When considering a location for the unit, it is recommended that a six (6) inch clearance be maintained on at least one side of the air conditioner. It is also recommended that twenty (20) inches of clearance be allowed from the front of the unit for cover removal.
6. Figure 1 and the cutout template included with the unit will assist in preparing the enclosure for installation of the unit. NOTE: Mount the unit within 3° from vertical.
7. Mount air conditioner on enclosure taking care not to damage the mounting gasket. The mounting gasket is the seal between the air conditioner and the enclosure. Avoid dragging the air conditioner on the enclosure with the mounting gasket attached as this could cause rips or tears in the gasket and risk losing the water tight seal.
8. Allow unit to remain upright for a minimum of five (5) minutes before starting. CAUTION! Air conditioner must be in upright position during operation.
9. Refer to the nameplate for electrical requirements. Wire the unit to a properly grounded power supply. Electrical circuit should be fused with slow blow or HACR circuit breaker.
10. Adjust the controller to the desired cabinet temperature. Refer to Displaying and Changing Program Variables on page 13 for controller adjustments and operation.



### CAUTION

### MISE EN GARDE

The unit is meant to be installed in an enclosure suitable for the environment listed previously and such that the field wiring and controls are only accessible with the use of a tool.

When installed on an enclosure, only the front/face side, ambient air in, and ambient air out can be exposed to the environment.

L'unité doit être installée dans une armoire adaptée à l'environnement susmentionné et de telle sorte que le câblage et les commandes sur le terrain ne soient accessibles qu'à l'aide d'un outil.

Lors d'une installation sur une armoire, seule la face avant/latérale, l'entrée d'air ambiant et la sortie d'air ambiant peuvent être exposées à l'environnement.

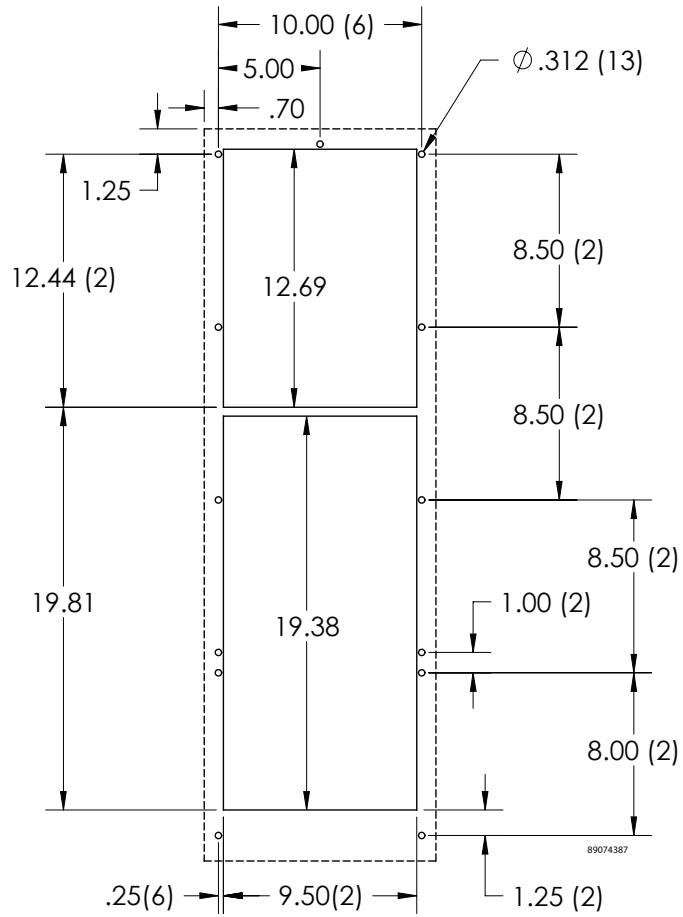

Surface Mount

Figure 1  
Cut-out Drawing

# SMART CONTROLLER

## INTRODUCTION

The smart controller is a parametric controller for the complete management of air conditioners. All settings are pre-programmed at the factory. Cooling set-points, cooling differential and high/low temperature alarm set-points can be adjusted by the user. Alarms are outputted through a relay contact.

## ENERGIZING THE CONTROLLER

The controller is wired and programmed at the factory to be energized when power is supplied to the air conditioner.

## CONTROL STATUS INDICATION

The display has numerous symbols that indicate if the controller is cooling or alarming, if the compressor is enabled, and if the ambient fan is enabled. The 3 alpha-numeric characters further describe alarms and show the cabinet temperature by default.

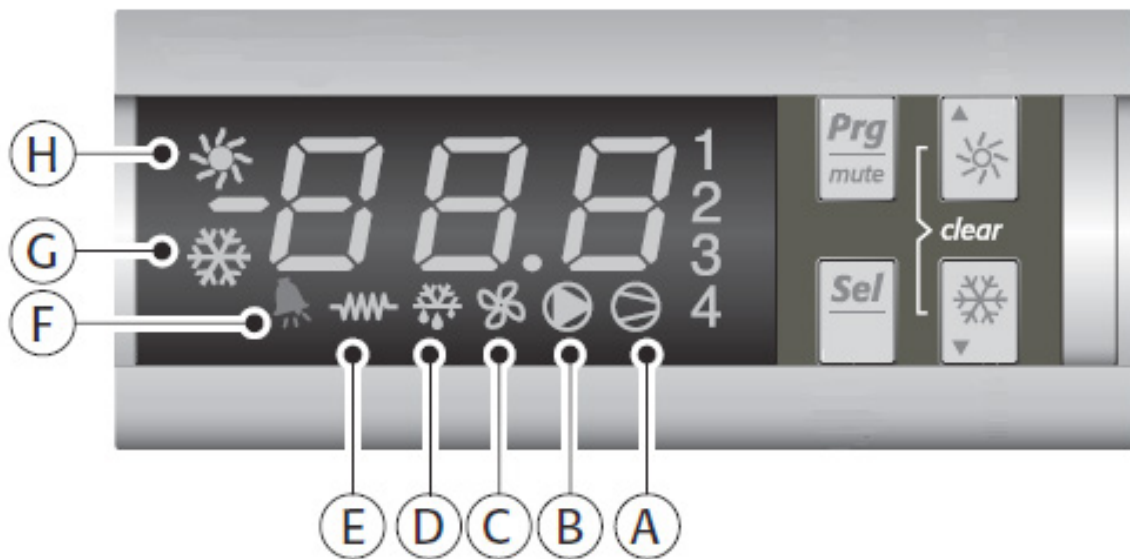

SYMBOL	COLOR	ICON ON	ICON FLASHING
1	AMBER	Compressor On	Start-up Request
2,3,4	AMBER	Not Used	Not Used
A	AMBER	Compressor On	Not Used
B	AMBER	Evaporator Fan On	Not Used
C	AMBER	Not Used	Not Used
D	AMBER	Not Used	Not Used
E	AMBER	Heater Active	Not Used
F	RED	Alarm Active	Not Used
G	AMBER	Controller Active	Not Used
H	AMBER	Not Used	Not Used

## DISPLAYING AND CHANGING PROGRAM VARIABLES

**Access:** To view and/or change parameters, press and hold the Prg and Sel buttons for greater than 5 seconds. Press the up or down arrow buttons until “22” is displayed, then press Sel button. When “S-P” is displayed, press Sel.

**Navigation:** Press up or down arrows to display sub-menus then press Sel to select the desired sub-menu. In the sub-menu, use up or down arrows to display parameters for viewing or changing and press Sel. Use Prg button to back out of menu levels as desired.

**Adjust:** Use the up or down arrows to change the parameter value then push Sel to save that setting. If Sel is not pressed, the change to the value will not be saved. Navigate to and change other parameters as desired. When finished, push Prg to back out of the sub-menus to the main menu.

**NOTE: The display will revert to normal temperature display mode if no buttons are pressed for 60 seconds.**

### OPERATING PARAMETERS

Parameter	Default Value	Range	Description
r01	80 F	72 F to 120 F	Cooling set-point
r02	7 F	-	Cooling differential
A04	50 F*	32 F to 60 F	Heating set-point*
A05	7 F*	-	Heating differential*

Cooling turns on at r01 + r02, and off at r01

Heating turns on at A04, and off at A04 + A05

\*Functional only on units with heater option

### ALARM PARAMETERS

Parameter	Default Value	Description
P16	125 F	High Temperature Alarm
P19	40 F	Low Temperature Alarm

## DISPLAYING TEMPERATURE SENSOR #2

Sensor number 2, the air outlet or condenser coil sensor, can be viewed at any time by pressing the up or down arrow button on the front panel of the controller display. The display will revert to displaying temperature sensor number 1 (the AC inlet temperature) after 60 seconds. Both sensors can also be read through the Ethernet and USB connections.

## COMPRESSOR RESTART TIME DELAY

A factory set 6 minute (360 second) restart delay exists to reduce residual back pressure before allowing the compressor to restart. The compressor will stay off for the entire restart duration after the compressor is disabled. A flashing one (1) on the controller display will indicate the unit is in a compressor restart delay while calling for cooling. If the time delay is reduced to less than five (5) minutes, this may cause reduced compressor life.

## ALARM OUTPUT CONTACT

The smart controller has a normally open, dry contact, alarm output with a resistive load rating of 24 VAC at 261 mA. A connector located on the enclosure side of the unit provides a 2-pin connection to this output marked YEL/ALARM.

## ALARM INPUT CONNECTION

The smart controller can accept a dry contact/switch input via the connector terminals marked WHT/DS1 and WHT/DS2 located on the enclosure side of the unit. This input is associated with the controller display alarm mnemonic TP (door open and/or smoke detected). To use this feature, remove the jumper wire connecting terminals DS1 and DS2 and replace with customer supplied wires from the enclosure door switch to DS1 and DS2 terminals.

## ALARM CONDITION DISPLAY

There are seven possible non-latching alarm conditions detectable by the controller and are indicated on the controller display. All alarms can also be accessed through the Ethernet and USB connections with the optional communications board.

Alarm Mnemonic	Description	Cause	Result	Alarm Relay
TP	General Alarm	Door open and/or smoke detected	Unit turns off for duration of alarm	Relay Contacts Close
LA	High Pressure Warning	MALF high pressure switch opens	No effect on function	N/A
E1	Air Inlet Temperature Sensor Alarm	Sensor Failure	Unit turns off for duration of alarm	Relay Contacts Close
E2	Air Outlet Temperature Sensor Alarm	Sensor Failure	Unit turns off for duration of alarm	Relay Contacts Close
Ht	High Temperature Alarm Default = 125 F	Cabinet over temperature Alarm clears at default setting -2 F	No effect on function	Relay Contacts Close
Lt	Low Temperature Alarm Default = 40 F	Cabinet under temperature Alarm clears at default setting +27 F	No effect on function	Relay Contacts Close
A1	Frost Alarm	Evaporator coil frozen Alarm clears at 59 F	Compressor fan off for duration of alarm	Relay Contacts Close

## REMOTE ACCESS CONTROL

### AIR CONDITIONER UNIT COMMUNICATION FEATURES

Air conditioner units equipped with communication capabilities provide SNMP, EtherNet/IP, Modbus TCP and Profinet protocols through Ethernet and Modbus RTU protocol via USB. Hoffman Cooling has a PC Interface Tool available for download that can utilize either mode to communicate with the air conditioner unit.

#### USB COMMUNICATION

This communication mode allows direct connection of a PC to the air conditioner unit. The protocol supported is Modbus RTU. Use the PC Interface Tool to communicate with the air conditioner unit. A MINI-b USB connection is provided.

#### ETHERNET COMMUNICATION

This communication mode allows remote connection to the air conditioner unit using SNMP, EtherNet/IP, Modbus TCP and Profinet protocols. Customers using their own software can download a MIB file for SNMP, EDS file or EtherNet\_IP Object file for EtherNet/IP and Coil\_Register file for Modbus TCP and GSDML file for Profinet.

**Note: ACU has a default IP Address of 192.168.1.2**

Both Ethernet and USB communication modes allow the ability to:

- Read ACU inlet and outlet air temperatures
- Read and change Cooling Set-point and Cooling Differential
- Read and change Heating Set-point, Heating Differential
- Read and change High and Low Temperature Alarm Settings
- Read and change Gateway IP Address, Device IP Address, Subnet Mask, Trap IP Address and Community
- Read and change Unit Identification
- Read and change the state of IP addressing (static or dynamic)
- Read current Alarm Status

#### SOFTWARE AND CONFIGURATION FILE DOWNLOADS

The PC Interface Tool, MIB file, EDS file, EtherNet\_IP Object file, Coil\_Register file and GSDML file for Profinet can be downloaded from:

[www.pentairprotect.com/en/na/Product-Enclosure-Cooling-Heating](http://www.pentairprotect.com/en/na/Product-Enclosure-Cooling-Heating)

## USING THE PC INTERFACE TOOL

The PC Interface Tool gives the user the ability to communicate with the air conditioner unit to read/write parameters using either Ethernet or USB connections.

### USB COMMUNICATION MODE

**NOTE: Before connecting unit to the PC, make note of the comm ports present. After the unit is connected to the PC, a new comm port will be added to the list. Use this new comm port.**

- From **Tools** menu select **Use Ethernet**
- When **Use Ethernet** is unchecked, then **Comm Port** menu is enabled, **Device IP** and **Community** boxes are not shown, and USB communication can be used
- To set the comm port, choose **Comm Port** from the **Tools** menu and then select the comm port from the combo box

### VIEWING AIR CONDITIONER UNIT VALUES

To view Air Conditioner Unit values

- Select the **ACU Values** tab
- Select the **Enable Comm** button (the PC Interface will now be communicating with unit)
- To stop communication select the **Disable Comm** button

### CHANGING AIR CONDITIONER UNIT VALUES

To change **ACU Values**

- Select the **Settings** tab
- Select the value to change
- Make the change to the value
- Select the **Change Setting** button
- Change can be verified in **ACU Values** tab

### VIEWING AND CHANGING ETHERNET INFORMATION

To view and change Ethernet Information

- Select **Ethernet Info** tab

To view Ethernet Information

- Click **Read Ethernet Info** button

To change to dynamically assigning IP Address Mode

- Check **Use DHCP Server** checkbox
- Enter Trap IP Address and Community
- Click **Load Ethernet Info** button

To change to statically assigning IP Address Mode

- Uncheck **Use DHCP Server** checkbox
- Enter Device IP Address, Subnet Mask, Gateway IP Address, Trap IP Address and Community
- Click **Load Ethernet Info** button



## ETHERNET COMMUNICATION MODE

- From **Tools** menu select **Use Ethernet**
- When **Use Ethernet** is checked, **Comm Port** selection is disabled, **Device IP** and **Community** boxes are shown and Ethernet communication can be used.
- Enter unit's IP Address and Community string in **Device IP** and **Community** boxes at the bottom of the PC Interface Tool.

**Each unit has two community strings. One is a Read/Write community string (defaulted to 'private') that can be changed by the customer (must be 4 to 8 characters long). The other is a Read-Only community string ('public') and cannot be changed.**

## VIEWING AIR CONDITIONER UNIT VALUES

To view Air Conditioner Unit values

- Select the **ACU Values** tab
- Select the **Enable Comm** button (the PC Interface will now be communicating with unit)
- To stop communication select the **Disable Comm** button

## CHANGING AIR CONDITIONER UNIT VALUES

To change **ACU Values**

- Select the **Settings** tab
- Select the value to change
- Make the change to the value
- Select the **Change Setting** button
- Change can be verified in **ACU Values** tab

## VIEWING AND CHANGING ETHERNET INFORMATION

To view and change Ethernet Information

- Select **Ethernet Info** tab

To view Ethernet Information

- Click **Read Ethernet Info** button

To change to dynamically assigning IP Address Mode

- Check **Use DHCP Server** checkbox
- Enter Trap IP Address and Community
- Click **Load Ethernet Info** button

To change to statically assigning IP Address Mode

- Uncheck **Use DHCP Server** checkbox
- Enter Device IP Address, Subnet Mask, Gateway IP Address, Trap IP Address and Community
- Click **Load Ethernet Info** button

## ALARM LOG ACCESSIBLE WITH SNMP

- Using custom software with the provided MIB file gives the ability to view a log of the last 25 alarms

## REMOTE ACCESS CONTROL PIN-OUT

	FUNCTION	NAME	PIN #
U1 OUTPUTS	COOL	No1	1
		C1/2	2
		C1/2	3
	ALARM RELAY OUTPUT	No5	12
		C5	6
U2 INPUTS	ENCLOSURE DOOR SWITCH	ID1	8
	MALFUNCTION NC SWITCH	ID2	1
	NA	ID3 (na)	9
	NA	ID4 (na)	2
	DIGITAL INPUT GROUND	ID GND	3
	T1, EVAP IN THERMISTOR	B1	13
	T2, EVAP OUT THERMISTOR	B2	12
	T1, T2 GND	GND	6
	NA	B3	11
	CONTROLLER POWER	G	7
	CONTROLLER POWER	G0	14
U3 DATA	POWER		1
	GROUND		2
	DIRECTION		3
	DATA		4

## GENERAL SAFETY INFORMATION

Please observe the following general safety instructions when assembling and operating the unit:

- Assembling, installing and servicing must only be performed by properly trained specialists.
- When transporting the enclosure with the cooling unit externally mounted, always use an additional shipping brace to support the cooling unit.
- Do not attempt to operate the air conditioner while it is horizontal or on its side, back or front.
- Factory-supplied replacement parts must be used.
- Repaired/replaced components must be located and wired in the identical location as the original components.
- Hazardous Location rating may be compromised if the above are not followed.
- Operation of air conditioner in areas containing airborne caustics or chemicals can rapidly degrade sealing properties of materials, deteriorate filters, refrigeration coils, blowers and motors. Contact Pentair Equipment Protection for special recommendations.



### DANGER



Danger: explosion hazard - do not energize, disconnect, or troubleshoot equipment unless power has been switched off or the area is known to be non-hazardous.

Unit to be installed and maintained by properly trained personnel only.

Danger: Risque d'explosion – Ne pas alimenter, déconnecter ni dépanner l'équipement si l'alimentation n'a pas été coupée ou si la zone n'est pas reconnue comme non dangereuse.

## **MAINTENANCE**

### **COMPRESSOR**

The compressor requires no maintenance. It is hermetically sealed, properly lubricated at the factory and should provide years of satisfactory operating service.

Under no circumstances should the access fitting covers be loosened, removed or tampered with.

Breaking of seals on compressor access fittings during warranty period will void warranty on hermetic system.

Recharging ports are provided for the ease and convenience of reputable refrigeration repair service personnel for recharging the air conditioner.

### **INLET AIR FILTER**

This air conditioner was designed with a dust resistant condenser coil. This allows it to be run filterless in most applications. The air conditioner is shipped with a filter in place for your convenience. For filterless operation, simply remove the filter. Should you decide the filter is necessary in your application, regular maintenance to clean this filter will assure normal operation of the air conditioner. The easily removable inlet air filter is located behind the inlet of the front cover. If necessary filter maintenance is delayed or ignored, the maximum ambient temperatures under which the unit is designed to operate will be decreased.

If the compressor's operating temperature increases above designed conditions due to a dirty or clogged filter (or plugged condenser coil), the air conditioner's compressor will stop operating due to actuation of the thermal overload cut-out switch located on the compressor housing. As soon as the compressor temperature has dropped to within the switch's cut-in setting, the compressor will restart automatically. However the above condition will continue to take place until the filter or coil has been cleaned. It is recommended that power to the air conditioner be interrupted intentionally when abnormally high compressor operating temperature causes automatic shut-down of the unit. The above described shut-down is symptomatic of a clogged or dirty filter, thus causing a reduction in cooling air flow across the surface of the compressor and condenser coil.

### **HOW TO REMOVE, CLEAN OR INSTALL A NEW INLET AIR FILTER**

RP aluminum washable air filters are designed to provide excellent filtering efficiency with a high dust holding capacity and a minimum amount of resistance to air flow. Because they are constructed entirely of aluminum they are lightweight and easy to service. To achieve maximum performance from your air handling equipment, air filters should be cleaned on a regular basis.

The inlet air filter is located behind the condenser air inlet grille. To access the filter, simply slide it out. The filter may now be cleaned or a new filter installed.

Cleaning Instructions:

1. Flush the filter with warm water from the exhaust side to the intake side. DO NOT USE CAUSTICS.
2. After flushing, allow filter to drain. Placing it with a corner down will assure complete drainage.

### **CONDENSATE MANAGEMENT AND DRAIN TRAP MAINTENANCE**

The drain trap can be cleaned by pouring soapy water into the face of the evaporator coil. An alternate method is to remove the panel underneath the condenser coil, locate the drain trap above the condensate evaporator pan, and blow compressed air through the tube.

## CONDENSER AND EVAPORATOR AIR MOVERS

Impeller motors require no maintenance. All bearings, shafts, etc. are lubricated during manufacturing for the life of the motor.

If the condenser impeller motors (ambient impellers) should fail, it is not necessary to remove the air conditioner from the cabinet or enclosure to replace the blower. The condenser impeller is mounted on its own bracket and is easily accessible by removing the front cover.

If the evaporator impeller motor should fail, it may require dismantling the unit from the enclosure because access to the evaporator is through the enclosure side. After it is repaired, refer to Installation Instructions on page 10 for mounting the unit back onto the enclosure. Replace the mounting gasket if damaged.



### CAUTION MISE EN GARDE

Operation of air conditioner in areas containing airborne caustics or chemicals can rapidly degrade sealing properties of materials, deteriorate filters, refrigeration coils, blowers and motors.

Contact Pentair Equipment Protection for special recommendations.

Le fonctionnement du climatiseur dans des espaces contenant des produits caustiques ou chimiques en suspension dans l'air peut rapidement dégrader les propriétés d'étanchéité des matériaux, détériorer les filtres, les serpentins du condenseur, les ventilateurs et les moteurs.

Communiquer avec Pentair Equipment Protection pour connaître les recommandations spéciales.

## REFRIGERANT LOSS

Each air conditioner is thoroughly tested prior to leaving the factory to insure against refrigeration leaks. Shipping damage or microscopic leaks not found with sensitive electronic refrigerant leak detection equipment during manufacture may require repair or recharging of the system. This work should only be performed by qualified professionals, generally available through a local, reputable air conditioning repair or service company.

Should the refrigerant charge be lost, access ports on the suction and discharge sides of the compressor are provided for recharging and/or checking suction and discharge pressures.

Refer to the data on the nameplate which specifies the type of refrigerant and the charge size in ounces.

Before recharging, make sure there are no leaks and that the system has been properly evacuated into a deep vacuum.

### REFRIGERANT PROPERTIES CHART (R134A)

°F	°C	Pressure	°F	°C	Pressure
-40	-40	-14.7	60	15.6	58
-35	-37.2	-12.3	65	18.3	64
-30	-34.4	-9.7	70	21.1	71.5
-25	-31.7	-6.8	75	23.9	78
-20	-28.9	-4	80	26.7	86.7
-15	-26.1	0	85	29.4	95
-10	-23.3	2	90	32.2	105
-5	-20.6	4	95	35	113.3
0	-17.8	7.5	100	37.8	125
5	-15	9	105	40.6	135
10	-12.2	12	110	43.3	146.7
15	-9.4	15	115	46.1	157.5
20	-6.7	18.5	120	48.9	170
25	-3.9	22	125	51.7	185
30	-1.1	26			
35	1.7	30			
40	4.4	35			
45	7.2	40			
50	10	45.5			
55	12.8	51.5			

## 6000 BTU/HR. UNIT CHARACTERISTICS

	Model		
	NHZ360616GXXX	NHZ360626GXXX	NHZ360646GXXX
<b>Dimensional Data</b>			
Height	36" / 914.4 mm		
Width	11.5" / 292.1 mm		
Depth	14" / 355.6 mm		
Unit Weight	100 lbs / 45 kg	100 lbs / 45 kg	104 lbs / 47 kg
Unit Protection Rating	Type 12/4/4X/3R Class 1 Division 2 Groups A, B, C, D and T4A		
<b>Cooling Data</b>			
Refrigerant	R134a		
Refrigerant Charge	20 oz.	22 oz.	16 oz.
Cooling Capacity at 95 F Enclosure 95 F Ambient (BTU/Hr.)	4909/5485	5159/5621	5572/6026
Cooling Capacity at Max Conditions (BTU/Hr.)	5585/6180	5469/5965	5700/6200
Maximum Ambient Temp	131 F / 55 C		
Minimum Ambient Temp	-40 F / -40 C		
Enclosure Airflow	250/261 CFM		
External Airflow	338/365 CFM		
Condensate Management	Hose discharge / Optional powered C/E		
<b>Electrical Data</b>			
Rated Voltage (50/60 Hz)	115 V	230 V	400/460 V 3 phase
Rated Frequency	50 / 60 Hz		
Voltage Range	+/- 10% of rated		
Cooling Amps at Max Conditions	9.1/10.1	4.5/4.7	1.7/1.8
Compressor RLA / LRA	5.5/39.2	2.4/23.0	1.7/8.1
Evaporator Fan RLA	.78/.93	.39/.53	.39/.53
Condenser Fan RLA	.78/.93	.39/.53	.39/.53

## 8000 BTU/HR. UNIT CHARACTERISTICS

	Model		
	NHZ360816GXXX	NHZ360826GXXX	NHZ360846GXXX
<b>Dimensional Data</b>			
Height	36" / 914.4 mm		
Width	11.5" / 292.1 mm		
Depth	14" / 355.6 mm		
Unit Weight	106 lbs / 48 kg`	106 lbs / 48 kg	114 lbs / 52 kg
Unit Protection Rating	Type 12/4/4X/3R Class 1 Division 2 Groups A, B, C, D and T4A		
<b>Cooling Data</b>			
Refrigerant	R134a		
Refrigerant Charge	36 oz.	36 oz.	36 oz.
Cooling Capacity at 95 F Enclosure 95 F Ambient (BTU/Hr.)	7028/7626	6660/7411	6877/7525
Cooling Capacity at Max Conditions (BTU/Hr.)	7421/8119	7874/8063	7571/8328
Maximum Ambient Temp	131 F / 55 C		
Minimum Ambient Temp	-40 F / -40 C		
Enclosure Airflow	245/258 CFM		
External Airflow	347/382 CFM		
Condensate Management	Hose discharge / Optional powered C/E		
<b>Electrical Data</b>			
Rated Voltage (50/60 Hz)	115 V	230 V	400/460 V 3 phase
Rated Frequency	50 / 60 Hz		
Voltage Range	+/- 10% of rated		
Cooling Amps at Max Conditions	11.2/12.4	5.5/6.1	3.0/3.4
Compressor RLA / LRA	6.0/48.3	3.2/27.0	2.0/16.0
Evaporator Fan RLA	.78/.93	.39/.53	.39/.53
Condenser Fan RLA	.78/.93	.39/.53	.39/.53

## FUNCTIONAL DATA

Unit	Evaporator. Air In(°F)	Amps(A)	Condenser Delta(°F)	Evaporator Delta(°F)
NHZ360616GXXX	65-80	5.1-6.7	17-25	14-23
	80-100	5.7-8.0	19-26	17-25
NHZ360626GXXX	65-80	2.3-3.6	19-28	15-23
	80-100	2.6-4.1	22-31	17-26
NHZ360646GXXX	65-80	1.3-1.8	12-23	13-15
	80-100	1.4-1.9	17-26	9-19
NHZ360816GXXX	65-80	5.7-7.6	21-30	17-30
	80-100	6.6-9.5	24-36	24-32
NHZ360826GXXX	65-80	3.0-4.5	25-37	12-20
	80-100	3.5-5.2	31-38	14-30
NHZ360846GXXX	65-80	1.9-2.8	27-36	18-31
	80-100	2.3-3.0	30-43	25-33

# SERVICE DATA

## 6000 BTU/HR. COMPONENTS LIST

Part Description	Part Number		
	115 V 1 PHASE	230 V 1 PHASE	460 V 3 PHASE
Capacitor, Compressor, Start	10103205SP	10103214SP	N/A
Capacitor, Condenser Impeller	52603213SP	52603214SP	52603214SP
Capacitor, Evaporator Impeller	52603213SP	52603214SP	52603214SP
Coil, Condenser	89068417SP	89068417SP	89068417SP
Coil, Evaporator	89068415SP	89068415SP	89068415SP
Coil, Evaporator E-coated	89114213SP	89114213SP	89114213SP
Compressor (See note below)	10101686SP	101026109SP	101096222SP
Filter, Air, Reusable	89068405SP	89068405SP	89068405SP
Filter/Dryer	52602800SP	52602800SP	52602800SP
Head Pressure Control Switch	89112571SP	89112571SP	89112571SP
Impeller, Condenser	89114225SP	89114226SP	89114226SP
Impeller, Evaporator	89114225SP	89114226SP	89114226SP
Encapsulated Compressor Start Relay	89110056SP	89114207SP	N/A
Thermal Expansion Valve	10104042SP	10104042SP	10104042SP
Transformer, Input Power	N/A	N/A	101006128SP
Controller, Basic	89075653SP	89075653SP	89075653SP
Thermistor	89075654SP	89075654SP	89075654SP
Bridge Rectifier	89087424SP	89087424SP	89087424SP
Controller Wires with pins (24)	89083091SP	89083091SP	89083091SP
Communication Board	89109039SP	89109039SP	89109039SP
Communication Cable	89080313SP	89080313SP	89080313SP
Fuse, Controller (315mA)	89085114SP	89085114SP	89085114SP
Encapsulated Compressor Overload	89114218SP	89114219SP	89114853SP
Solid State Relay	89114223SP	89114223SP	89114224SP
Overload Relay	89115269SP	89098326SP	89115543SP
Mounting Gasket	89114210SP	89114210SP	89114210SP
Mounting Kit	43785003SP	43785003SP	43785003SP
Stainless Steel Mounting Kit	89116253SP	89116253SP	89116253SP



### DANGER



Danger: explosion hazard - Substitution or incorrect installation of components may void the suitability for hazardous location use.

Danger: Risque d'explosion - Le remplacement ou une mauvaise installation des composants peuvent rendre l'équipement inadapté à une utilisation en zone dangereuse.

**Note: This design utilizes an encapsulated compressor overload, which is mounted on the side of the compressor body. If the compressor is replaced, the standard overload (included with the compressor) must be discarded and not used. An encapsulated overload must be mounted and wired identical to the original.**



## 8000 BTU/HR. COMPONENTS LIST

Part Description	Part Number		
	115 V 1 PHASE	230 V 1 PHASE	460 V 3 PHASE
Capacitor, Compressor, Start	10103208SP	10103208SP	N/A
Capacitor, Condenser Impeller	52603213SP	52603214SP	52603214SP
Capacitor, Evaporator Impeller	52603213SP	52603214SP	52603214SP
Coil, Condenser	89068401SP	89068401SP	89068401SP
Coil, Evaporator	89068402SP	89068402SP	89068402SP
Coil, Evaporator E-coated	89114214SP	89114214SP	89114214SP
Compressor (See note below)	10101685SP	101026107SP	101026122SP
Filter, Air, Reusable	89068405SP	89068405SP	89068405SP
Filter/Dryer	52602800SP	52602800SP	52602800SP
Head Pressure Control Switch	89112571SP	89112571SP	89112571SP
Impeller, Condenser	89114225SP	89114226SP	89114226SP
Impeller, Evaporator	89114225SP	89114226SP	89114226SP
Encapsulated Compressor Start Relay	89113305SP	89114208SP	N/A
Thermal Expansion Valve	89074083SP	89074083SP	89074083SP
Transformer, Input Power	N/A	N/A	101006128SP
Controller, Basic	89075653SP	89075653SP	89075653SP
Thermistor	89075654SP	89075654SP	89075654SP
Bridge Rectifier	89087424SP	89087424SP	89087424SP
Controller Wires with pins (24)	89083091SP	89083091SP	89083091SP
Communication Board	89109039SP	89109039SP	89109039SP
Communication Cable	89080313SP	89080313SP	89080313SP
Fuse, Controller (315mA)	89085114SP	89085114SP	89085114SP
Encapsulated Compressor Overload	89114220SP	89114854SP	89114221SP
Solid State Relay	89114223SP	89114223SP	89114224SP
Overload Relay	89115269SP	89118486SP	89116764SP
Mounting Gasket	89114210SP	89114210SP	89114210SP
Mounting Kit	43785003SP	43785003SP	43785003SP
Stainless Steel Mounting Kit	89116253SP	89116253SP	89116253SP



### DANGER



Danger: explosion hazard - Substitution or incorrect installation of components may void the suitability for hazardous location use.

Danger: Risque d'explosion – Le remplacement ou une mauvaise installation des composants peuvent rendre l'équipement inadapté à une utilisation en zone dangereuse.

**Note: This design utilizes an encapsulated compressor overload, which is mounted on the side of the compressor body. If the compressor is replaced, the standard overload (included with the compressor) must be discarded and not used. An encapsulated overload must be mounted and wired identical to the original.**

## NHZ360616GXXX PRESSURE TABLES

NHZ360616GXXX 50hz		L=SUCTION (± 5PSIG); H=HEAD (-10/+20PSIG)															
Ambient Temperature (°F)		ENCLOSURE TEMPERATURE (°F)															
		70		80		90		95		100		113		120		131	
		L	H	L	H	L	H	L	H	L	H	L	H	L	H	L	H
70		35	113	42	120	48	126	51	129	55	133	63	141	68	146	75	153
80		37	138	44	145	51	152	55	156	58	160	67	169	72	174	80	182
90		39	163	47	171	54	179	58	183	62	187	72	197	77	202	85	210
95		40	176	48	184	56	192	57	186	63	200	74	210	79	216	88	225
100		41	189	49	197	57	205	61	209	65	213	76	224	81	230	90	239
113		43	222	52	231	61	240	65	244	70	249	81	260	87	266	97	276
120		45	239	54	249	63	258	68	263	72	267	84	280	90	286	100	296
131		47	267	57	277	66	287	71	292	76	297	89	310	95	317	106	328

NHZ360616GXXX 60hz		L=SUCTION (± 5PSIG); H=HEAD (-10/+20PSIG)															
Ambient Temperature (°F)		ENCLOSURE TEMPERATURE (°F)															
		70		80		90		95		100		113		120		131	
		L	H	L	H	L	H	L	H	L	H	L	H	L	H	L	H
70		32	116	38	123	44	130	47	133	50	137	58	146	62	150	69	158
80		34	142	40	149	47	157	50	161	53	164	62	174	67	180	74	188
90		36	167	43	176	50	184	53	188	57	192	66	203	71	209	79	218
95		37	180	44	189	51	197	52	191	58	206	68	218	73	224	81	233
100		37	193	45	202	52	211	56	216	60	220	70	232	75	238	83	248
113		40	226	48	236	56	246	60	251	64	256	75	269	80	277	89	288
120		41	244	50	255	58	265	62	270	66	276	77	290	83	297	93	309
131		43	272	52	283	61	295	66	301	70	306	82	321	88	329	98	342

## NHZ360626GXXX PRESSURE TABLES

NHZ360626GXXX 50hz			L=SUCTION (± 5PSIG); H=HEAD (-10/+20PSIG)														
Ambient Temperature (°F)	ENCLOSURE TEMPERATURE (°F)																
	°F	70		80		90		95		100		113		120		131	
		L	H	L	H	L	H	L	H	L	H	L	H	L	H	L	H
70	35	118	42	124	48	131	52	134	55	137	64	145	69	150	76	157	
80	37	143	44	150	52	157	55	160	59	164	68	172	73	177	81	184	
90	39	169	47	176	55	183	59	186	63	190	73	199	78	204	87	212	
95	40	182	48	189	56	196	57	189	65	203	75	212	81	218	90	225	
100	41	194	50	202	58	209	62	213	66	216	77	226	83	231	92	239	
113	44	227	53	235	62	243	67	247	71	251	83	261	89	266	99	275	
120	46	245	55	253	64	261	69	265	74	269	86	279	93	285	103	294	
131	48	273	58	281	68	290	73	294	78	298	91	309	98	315	109	324	

NHZ360626GXXX 60hz			L=SUCTION (± 5PSIG); H=HEAD (-10/+20PSIG)														
Ambient Temperature (°F)	ENCLOSURE TEMPERATURE (°F)																
	°F	70		80		90		95		100		113		120		131	
		L	H	L	H	L	H	L	H	L	H	L	H	L	H	L	H
70	33	123	39	129	45	135	48	139	51	142	58	150	63	154	69	161	
80	35	149	41	155	48	162	51	166	54	169	62	178	67	183	74	190	
90	37	174	44	182	50	189	54	193	57	196	66	206	71	211	79	219	
95	38	187	45	195	52	202	52	196	59	210	68	220	73	225	81	234	
100	38	200	46	208	53	216	57	220	61	223	70	234	76	239	84	248	
113	41	233	49	242	57	250	61	255	65	259	76	270	81	276	90	286	
120	42	251	50	260	59	269	63	273	67	278	78	290	84	296	94	306	
131	44	279	53	289	62	298	67	303	71	308	83	321	89	327	99	338	

## NHZ360646GXXX PRESSURE TABLES

NHZ360646GXXX 50hz		L=SUCTION (± 5PSIG); H=HEAD (-10/+20PSIG)															
Ambient Temperature (°F)		ENCLOSURE TEMPERATURE (°F)															
		70		80		90		95		100		113		120		131	
		L	H	L	H	L	H	L	H	L	H	L	H	L	H	L	H
70		35	126	41	133	48	140	51	144	54	148	62	157	67	162	74	170
80		37	154	44	161	51	169	54	173	58	176	67	186	72	192	80	200
90		39	181	47	189	54	197	58	201	62	205	72	216	77	221	85	230
95		40	195	48	203	56	211	57	213	64	220	74	230	79	236	88	245
100		41	209	49	217	57	225	61	230	65	234	76	245	82	251	91	260
113		43	244	52	253	61	262	66	267	70	271	82	283	88	289	98	299
120		45	264	54	273	64	282	68	287	73	291	85	303	92	310	102	320
131		47	294	57	304	67	313	72	318	77	323	90	336	97	342	108	353

NHZ360646GXXX 60hz		L=SUCTION (± 5PSIG); H=HEAD (-10/+20PSIG)															
Ambient Temperature (°F)		ENCLOSURE TEMPERATURE (°F)															
		70		80		90		95		100		113		120		131	
		L	H	L	H	L	H	L	H	L	H	L	H	L	H	L	H
70		32	128	38	136	44	143	47	147	50	151	58	161	62	167	69	175
80		34	156	40	164	47	173	50	177	53	181	62	191	66	197	74	206
90		36	185	43	193	50	202	53	206	57	210	66	221	71	227	78	237
95		37	199	44	208	51	216	53	216	58	225	68	236	73	242	80	252
100		38	213	45	222	53	231	56	235	60	240	70	251	75	258	83	267
113		40	250	48	259	56	269	60	274	64	278	74	291	80	297	89	308
120		42	270	50	280	58	289	62	294	66	299	77	312	83	318	92	329
131		44	301	53	311	61	321	66	326	70	331	81	345	87	352	97	363

## NHZ360816GXXX PRESSURE TABLES

NHZ360816GXXX 50hz		L=SUCTION (± 5PSIG); H=HEAD (-10/+20PSIG)															
Ambient Temperature (°F)		ENCLOSURE TEMPERATURE (°F)															
		70		80		90		95		100		113		120		131	
		L	H	L	H	L	H	L	H	L	H	L	H	L	H	L	H
70	34	124	39	131	45	138	48	142	50	145	57	154	61	159	67	167	
80	36	152	42	160	47	168	50	172	53	176	61	186	65	191	71	200	
90	37	180	44	189	50	197	53	202	56	206	64	218	69	224	76	233	
95	38	194	45	203	51	212	53	208	58	221	66	233	71	240	78	250	
100	39	208	46	218	52	227	56	232	59	237	68	249	73	256	80	266	
113	41	245	48	255	56	266	59	271	63	276	73	290	78	298	86	309	
120	42	264	50	275	58	287	61	292	65	298	75	312	81	320	89	333	
131	44	295	52	307	60	319	64	325	69	331	79	347	85	356	94	369	

NHZ360816GXXX 60hz		L=SUCTION (± 5PSIG); H=HEAD (-10/+20PSIG)															
Ambient Temperature (°F)		ENCLOSURE TEMPERATURE (°F)															
		70		80		90		95		100		113		120		131	
		L	H	L	H	L	H	L	H	L	H	L	H	L	H	L	H
70	30	124	35	132	40	141	43	145	46	149	53	160	56	166	62	175	
80	32	153	37	162	43	171	45	176	48	180	55	192	59	198	65	208	
90	33	182	39	192	45	201	48	206	51	211	58	224	62	230	69	241	
95	34	197	40	207	46	216	49	215	52	226	60	239	64	246	71	257	
100	35	211	41	221	47	232	50	237	53	242	61	255	66	263	72	274	
113	37	249	44	260	50	271	53	277	57	282	65	297	70	304	77	317	
120	38	269	45	281	52	292	55	298	58	304	67	319	72	327	79	340	
131	40	301	47	313	54	326	58	332	61	338	70	354	75	362	83	376	

## NHZ360826GXXX PRESSURE TABLES

NHZ360826GXXX 50hz			L=SUCTION (± 5PSIG); H=HEAD (-10/+20PSIG)														
Ambient Temperature (°F)	ENCLOSURE TEMPERATURE (°F)																
	°F	70		80		90		95		100		113		120		131	
		L	H	L	H	L	H	L	H	L	H	L	H	L	H	L	H
70	33	134	39	141	44	148	47	152	50	155	57	162	61	169	67	177	
80	34	163	40	171	46	179	49	183	52	187	60	195	64	203	71	211	
90	36	192	42	201	48	209	52	214	55	218	63	227	68	236	75	246	
95	36	206	43	215	49	225	52	224	56	234	65	243	69	253	76	263	
100	37	221	44	230	51	240	54	245	57	250	66	260	71	270	78	280	
113	39	249	46	260	53	271	57	276	61	282	70	292	75	303	83	315	
120	40	278	47	290	55	301	59	307	62	313	72	325	78	336	86	349	
131	41	310	49	323	57	335	61	342	65	348	76	360	81	373	90	387	

NHZ360826GXXX 60hz			L=SUCTION (± 5PSIG); H=HEAD (-10/+20PSIG)														
Ambient Temperature (°F)	ENCLOSURE TEMPERATURE (°F)																
	°F	70		80		90		95		100		113		120		131	
		L	H	L	H	L	H	L	H	L	H	L	H	L	H	L	H
70	30	136	35	145	40	153	43	157	46	162	53	173	56	179	62	188	
80	31	166	37	176	42	185	45	189	48	194	55	205	59	212	65	222	
90	33	197	39	207	44	216	47	221	50	226	57	238	61	245	67	255	
95	34	212	39	222	45	232	48	231	51	242	58	254	62	261	69	272	
100	34	227	40	238	46	248	49	253	52	258	59	271	63	278	70	289	
113	36	267	42	278	48	289	51	294	55	299	62	313	67	321	73	333	
120	37	288	44	300	50	311	53	316	56	322	64	336	68	344	75	356	
131	39	322	45	334	52	345	55	351	58	357	66	372	71	380	78	393	

## NHZ360846GXXX PRESSURE TABLES

NHZ360846GXXX 50hz		L=SUCTION (± 5PSIG); H=HEAD (-10/+20PSIG)															
Ambient Temperature (°F)		ENCLOSURE TEMPERATURE (°F)															
		70		80		90		95		100		113		120		131	
		L	H	L	H	L	H	L	H	L	H	L	H	L	H	L	H
70		30	139	35	148	40	157	42	161	44	166	50	177	54	183	59	193
80		32	169	37	179	42	188	44	193	47	198	53	210	57	217	62	228
90		33	199	39	209	44	220	47	225	49	230	56	244	60	251	66	262
95		34	214	40	225	45	235	47	228	51	246	58	260	62	268	68	279
100		35	229	41	240	46	251	49	257	52	262	59	277	63	285	69	297
113		37	268	43	280	49	292	52	298	55	304	63	320	67	328	74	342
120		38	289	44	302	51	314	54	321	57	327	65	343	69	352	76	366
131		40	322	47	335	53	349	56	356	60	362	68	380	73	389	80	404

NHZ360846GXXX 60hz		L=SUCTION (± 5PSIG); H=HEAD (-10/+20PSIG)															
Ambient Temperature (°F)		ENCLOSURE TEMPERATURE (°F)															
		70		80		90		95		100		113		120		131	
		L	H	L	H	L	H	L	H	L	H	L	H	L	H	L	H
70		27	138	32	148	36	158	38	163	41	168	47	182	50	189	55	200
80		29	170	33	180	38	191	40	196	43	201	49	215	52	222	57	233
90		30	201	35	212	40	223	42	228	45	234	51	248	54	255	60	267
95		31	217	36	228	41	239	43	233	46	250	52	264	55	272	61	284
100		32	233	37	244	42	255	44	261	47	266	53	280	56	288	62	300
113		34	274	39	285	44	297	47	303	49	308	56	323	59	331	65	344
120		35	296	40	308	45	319	48	325	51	331	57	346	61	354	66	367
131		37	331	42	343	47	355	50	361	53	367	60	382	63	391	69	404

# TROUBLE SHOOTING

## BASIC AIR CONDITIONING TROUBLE SHOOTING CHECK LIST - SMART CONTROLLER

1. Check manufacturer's nameplate located on the unit for correct power supply.
2. Turn on power to the unit. The controller will display a start up sequence then revert to the normal temperature display mode. Is the correct enclosure temperature displayed?

**Note: The temperature may be alternating with an alarm code.**

YES, proceed to step 3.
NO, possible problem: <ul style="list-style-type: none"><li>• Open controller fuse</li><li>• Controller in alarm condition. See Alarm Condition Display on page 14.</li><li>• Defective controller</li><li>• Defective thermistor - check by blowing warm air across the thermistor. If display temperature rises, thermistor is operable.</li></ul>

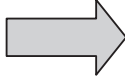

**Replace part**

3. The cooling status indication (symbol G) should be on. Is the symbol on? If not, press and hold the lower right "snowflake" button for greater than five seconds. Is the cooling mode symbol now on?

YES, proceed to step 4.
NO, possible problem: <ul style="list-style-type: none"><li>• Defective controller</li></ul>

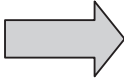

**Replace part**

4. The evaporator (Enclosure or "COLD" air) fan/impeller should turn on. Is there airflow?

YES, proceed to step 5.
NO, possible problem: <ul style="list-style-type: none"><li>• Controller in alarm condition. See Alarm Condition Display on page 14.</li><li>• Open motor winding</li><li>• Stuck fan/impeller</li><li>• Obstructed blades/wheel</li><li>• Defective motor capacitor</li></ul>

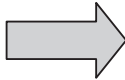

**Repair or Replace defective part**

5. Start the cooling cycle by changing the cooling setpoint parameter (r01) to the low limit of 72 F (22 C). Symbol 1 should be displayed indicating a call for cooling. If symbol 1 is flashing, the unit is in Restart Time Delay mode. Within 6 minutes, symbol 1 should display without flashing. Is symbol 1 displayed without flashing?

YES, proceed to step 8.
NO, possible problem: <ul style="list-style-type: none"><li>• Unit still in Recycle Time Delay mode</li><li>• Enclosure temperature below cooling setpoint temperature</li></ul>

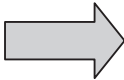

**Wait and/or heat enclosure thermistor T1**

6. The compressor and the condenser (Ambient or "HOT" air) impeller(s) should turn on. Is there adequate airflow?

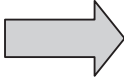

YES, proceed to step 7.	
NO, possible problem:	
<ul style="list-style-type: none"> <li>• Open motor winding(s)</li> <li>• Stuck impeller(s)</li> <li>• Obstructed wheel(s)</li> <li>• Defective motor capacitor(s)</li> </ul>	
	<div style="background-color: black; color: white; padding: 5px; display: inline-block;"><b>Repair or Replace defective part</b></div>

7. Carefully check the compressor for proper operation - motor should cause slight vibration and the outer case of the compressor should be warm. Is the compressor showing signs of this?

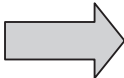
YES, wait 5 minutes, proceed to step 8.	
NO, possible problem:	
<ul style="list-style-type: none"> <li>• Defective start or run capacitor</li> <li>• Defective overload</li> <li>• Defective start relay</li> <li>• Defective contactor</li> <li>• Defective compressor</li> <li>• Tripped overload relay</li> </ul>	
	<div style="background-color: black; color: white; padding: 5px; display: inline-block;"><b>Reset, Repair or Replace defective part</b></div>

8. Make sure the coils are clean then check the evaporator “air in” and “air out” temperatures. If the temperatures are the same:

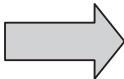
<ul style="list-style-type: none"> <li>• Possible loss of refrigerant</li> <li>• Possible bad valves in compressor</li> </ul>		<div style="background-color: black; color: white; padding: 5px; display: inline-block;"><b>Repair or Replace defective part</b></div>
---	---	--

## SYMPTOMS AND POSSIBLE CAUSES - REMOTE ACCESS CONTROL VERSION

SYMPTOM	POSSIBLE CAUSE
Unit won't cool	Clogged fins on coil(s)
	Dirty filter
	Impellers not running
	Compressor not running
	Compressor runs, but has bad valves
	Loss of refrigerant
Compressor tries to start but won't run	Low line voltage at start. Should be +/-10% rated voltage.
	Compressor motor stuck
	Bad contactor
	Bad overload switch
	Bad run/start capacitor
Unit blows breakers	Undersized breaker/fuse or not time delayed
	Short in system
Getting water in enclosure	Drain plugged
	Drain tube kinked
	Enclosure not sealed (allowing humidity in)
	Mounting gasket damaged

**For additional technical support, contact Pentair Equipment Protection at 800-896-2665.**

## WARRANTY

Pentair Equipment Protection warrants that the Goods manufactured by Pentair Equipment Protection will be free from defects in material and workmanship for a period of one (1) year from the date of shipment by Pentair Equipment Protection, subject to the following conditions and exclusions:

- A. Conditions. All Goods must be installed and operated according to the following specifications:
1. Maximum voltage variation no greater than plus or minus 10% of nameplate nominal rating;
  2. Maximum frequency variation no greater than plus or minus 3 Hz of nameplate nominal rating;
  3. Must not exceed minimum and maximum stated temperatures on the nameplate;
  4. Must not exceed (BTU/Hr) rating, including any heat sink as indicated on the nameplate;
  5. Refrigerant bearing Goods must not be restarted for a period of one (1) minute after intentional or accidental shut-off;
  6. The filters (if applicable) must be cleaned regularly;
  7. The Goods and any parts thereof must not be modified, unless prior written authorization is received from Pentair Equipment Protection; and
  8. All Goods must be installed and grounded in accordance with all relevant electrical and safety codes, as well as the National Electric Code and OSHA rules and regulations.
  9. All Goods must be installed in a stationery application, free of vibration.

A violation of any one of these conditions shall render the warranty hereunder void and of no effect.

- B. Exclusions. This warranty shall be void if product is misapplied in any way or:
1. Buyer specified product is inappropriate for system or environment in which it is operating.
  2. Goods are not installed in accordance with Pentair Equipment Protection specifications.
  3. Removal or modification of Pentair Equipment Protection label affixed to product without written Pentair Equipment Protection approval.

Pentair Equipment Protection must be notified of a claim in writing not later than fourteen (14) days from the date when Buyer has become aware of such occurrence, or where the defect is such that it may cause damage, immediately, such notice containing a description of how the defect manifests itself. Failure to provide such prompt notice to Pentair Equipment Protection shall result in forfeiture of Buyer's rights under this warranty.

In the event of a warranty claim, Buyer is to return defective goods to Pentair Equipment Protection in accordance with Pentair Equipment Protection Return Policy. Warranty period for repaired goods remains at 1 year from shipment of original goods. Pentair Equipment Protection sole obligation to Buyer under this warranty will be, at Pentair Equipment Protection option:

- A. Repair or replace Pentair Equipment Protection products or parts found to be defective in material or workmanship.
- B. Issue credit for the purchase price paid by Buyer relating to such defective Goods or part.

THIS WARRANTY CONSTITUTES THE ENTIRE WARRANTY WITH RESPECT TO THE GOODS AND IS IN LIEU OF ALL OTHER WARRANTIES, EXPRESSED OR IMPLIED, INCLUDING ANY IMPLIED WARRANTY OF MERCHANTABILITY AND IMPLIED WARRANTY OF FITNESS FOR A PARTICULAR PURPOSE.

## RETURN AND REPAIR POLICY

Pentair Equipment Protection products that: (i) are made to order, (ii) have been modified by Buyer, (iii) have special finishes, or (iv) are determined by Pentair Equipment Protection to constitute "custom" products that cannot be returned to stock or resold to other Buyers, will not be accepted for return by Pentair Equipment Protection.

All returns require a Return Material Authorization number (RMA #), regardless of reason for return, whether it be for warranty or out of warranty repair. Returns without an RMA # will be refused by our Receiving Department. An RMA # is valid for 30 days.

- A. An RMA # will be issued by our Product Return Department in Anoka, MN at 763-422-2211. Buyer should have following information available at time of RMA request:
1. Complete Model Number, Serial Number and description of damaged unit being returned.
  2. Original Buyer Purchase Order number and date product was received by Buyer.
  3. Quantity to be returned and a brief description of failure for each unit, if different.
  4. Contact information of Buyer that must include: name of company, billing and shipping address, phone, number, fax number, freight carrier and the name and phone number of a Buyer contact who can elaborate on the claimed defect in detail.
  5. Buyer must provide a Repair Purchase Order number for both warranty and out of warranty repairs. The PO will not exceed 50% of a new unit. Buyer will be notified of repair charges that exceed approved PO amount.
- B. All returns to Pentair Equipment Protection must be securely packed, using original cartons if possible. All returns must have the RMA number visible on the outside of the carton. Pentair Equipment Protection is not responsible for material damaged in transit. Any refrigerant-bearing Goods must be shipped upright for return.
- C. Shipping cost for all non-warranty repairs is the responsibility of the sender and must be shipped prepaid. Shipping costs for all warranty related repairs will be covered by Pentair Equipment Protection provided the goods are returned using a Pentair Equipment Protection approved carrier. If after diagnoses the product is determined by Pentair Equipment Protection not be covered under warranty, Buyer will be responsible for all shipping charges and will be billed accordingly.
- D. Non-warranty repairs are subject to a \$105 minimum analysis fee. If approval is not received within 30 days, material will be scrapped and all shipping expenses and corresponding analysis fees will be billed to Buyer.
- E. At Buyer's request, Failure Analysis can be provided by Pentair Equipment Protection for warrantable goods at no charge. Failure analysis for non-warranty repairs are subject to a \$150 per hour Engineering charge plus any other incurred testing costs.
- F. All returned merchandise must be sent to the following address: Pentair Equipment Protection, 2100 Hoffman Way, Anoka, MN 55303-1745.
- G. Credit for accepted returns shall be at the original selling price or the current selling price, whichever is lower, less the restocking charge indicated as follows:
1. Within 60 days of invoice date - 20% of applicable selling price.
  2. Within 61-120 days of invoice date - 30% of applicable selling price.
  3. Within 121-180 days of invoice date - 40% of applicable selling price.
  4. Beyond 180 days - subject to individual review by Pentair Equipment Protection.
- If product being returned for credit requires repair or modification, the cost of any labor or material necessary to bring product into saleable condition will be deducted from credit. Buyer may not take credit against returns without prior written Pentair Equipment Protection approval.

## **LIMITATION OF LIABILITY**

PENTAIR EQUIPMENT PROTECTION WILL NOT BE LIABLE UNDER ANY CIRCUMSTANCES FOR ANY INCIDENTAL, CONSEQUENTIAL OR SPECIAL DAMAGES, INCLUDING WITHOUT LIMITATION ANY LOST PROFITS OR LABOR COSTS, ARISING FROM THE SALE, USE OR INSTALLATION OF THE GOODS, FROM THE GOODS BEING INCORPORATED INTO OR BECOMING A COMPONENT OF ANOTHER PRODUCT, FROM ANY BREACH OF THIS AGREEMENT OR FROM ANY OTHER CAUSE WHATSOEVER, WHETHER BASED ON WARRANTY (EXPRESSED OR IMPLIED) OR OTHERWISE BASED ON CONTRACT, OR ON TORT OR OTHER THEORY OF LIABILITY, AND REGARDLESS OF ANY ADVICE OR REPRESENTATIONS THAT MAY HAVE BEEN RENDERED BY PENTAIR EQUIPMENT PROTECTION CONCERNING THE SALE, USE OR INSTALLATION OF THE GOODS.



Pentair Equipment Protection  
2100 Hoffman Way  
Minneapolis, MN 55303 USA

☎ +1.763.422.2211  
📠 +1.763.576.3200

**PentairProtect.com**