

RACK-MOUNTABLE ASSEMBLIES

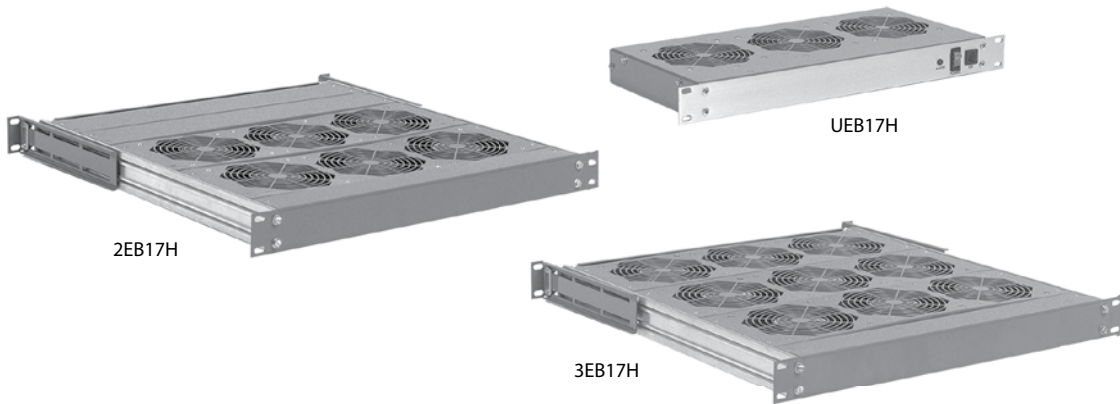

INDUSTRY STANDARDS

UL recognized

- CSA Certified Motors
- CE

APPLICATION

Fan trays are a versatile solution to cooling card cages and racks. Redundant cooling with optional failure detection makes this air mover the obvious choice for sensitive equipment. Minimal rack space and repositionable fans are suited to today's smaller enclosures.

FEATURES

- Slim 1.75 in. (44 mm) Panel Height
- 19-in. rack mountable
- Field adjustable fan strips to optimize air flow
- Easy access to fan tray from front and back
- Simplified installation without the need for side access
- Support bracket
- Exhaust Guard
- 6-inch Power Cord AC trays, Terminal block on DC trays
- Permanently lubricated ball bearing motors
- 100% functionally tested

SPECIFICATIONS

- 115/230 VAC
- 24 VDC
- 50/60 Hz

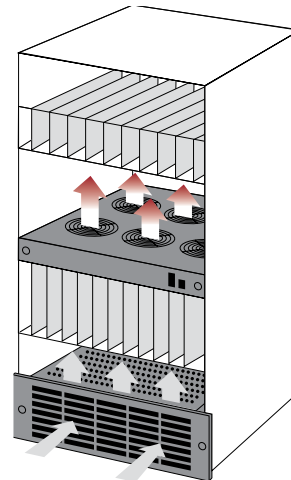

Performance Curves (Inches of Water to CFM)

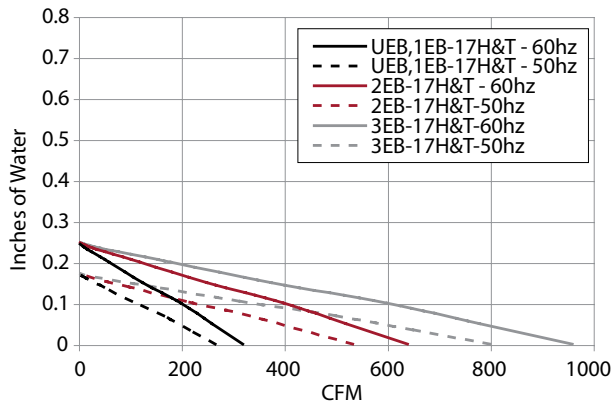

Performance Curves (Pa to m³/hr)

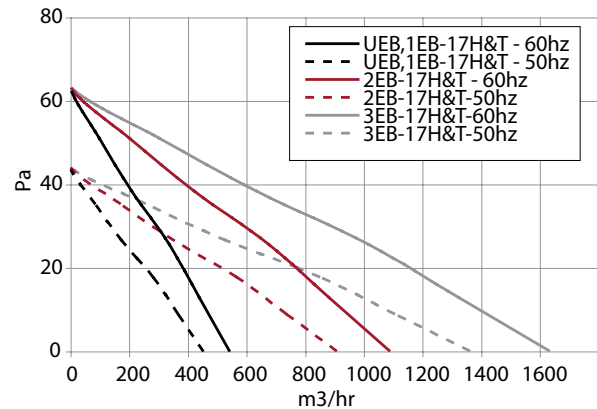

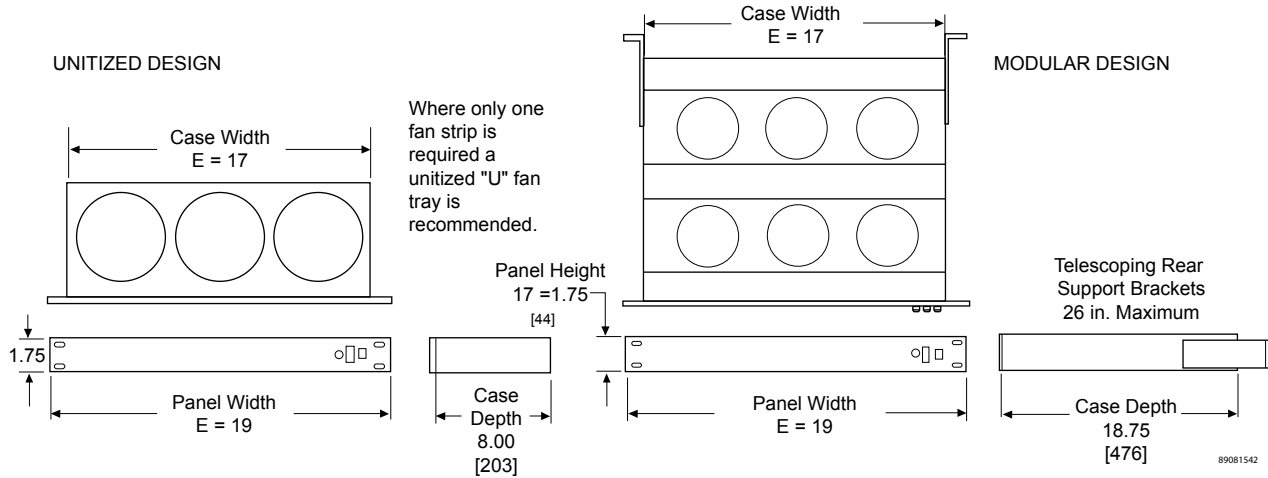

Performance Data **Rack-Mountable Assemblies**

ELECTRICAL DATA			
Rated Voltage	115 VAC	230 VAC	24 VDC
Frequency (Hz)	50/60	50/60	DC
RPM	3100	3100	3000
Nominal Current Maximum (Amps)	0.4	0.2	0.8
Power Consumption Maximum (Watts)	42	42	21
Maximum Operating Temperature (°F/°C)		158/70	
UEB17H			
Catalog Numbers	UEB17H115	UEB17H230	UEB17H24
Nominal Current Maximum @50/60 Hz (Amps)	.4	.2	.8
Power Consumption Maximum @ 50/60 Hz (Watts)	42	42	21
Free Airflow @ 50/60 Hz (CFM)*	315	315	330
Free Airflow @ 50/60 Hz (m ³ /hr.)*	536	536	561
Number of Fans	3		
Unit Dimensions H x W x D (In./mm)	1.75 x 19.00 x 8.00/44 x 482 x 203		
Weight (lb./kg)	7.8/3.4	7.8/3.4	7.6/3.3
2EB17H			
Catalog Numbers	2EB17H115	2EB17H230	—
Nominal Current Maximum @50/60 Hz (Amps)	.9	.5	—
Power Consumption Maximum @ 50/60 Hz (Watts)	84	84	—
Free Airflow @ 50/60 Hz (CFM)*	630	630	—
Free Airflow @ 50/60 Hz (m ³ /hr.)*	1071	1071	—
Number of Fans	6		
Unit Dimensions H x W x D (In./mm)	1.75 x 19.00 x 18.75/44 x 482 x 476		
Weight (lb./kg)	10.2/4.5	10.2/4.5	—
3EB17H			
Catalog Numbers	3EB17H115	3EB17H230	—
Nominal Current Maximum @50/60 Hz (Amps)	1.4	.8	—
Power Consumption Maximum @ 50/60 Hz (Watts)	126	126	—
Free Airflow @ 50/60 Hz (CFM)*	945	945	—
Free Airflow @ 50/60 Hz (m ³ /hr.)*	1607	1607	—
Number of Fans	9		
Unit Dimensions H x W x D (In./mm)	1.75 x 19.00 x 18.75/44 x 482 x 476		
Weight (lb./kg)	12.5/5.5	12.5/5.5	—